



**eka**<sup>®</sup>

# MILLENNIAL COOKING

We make it easy.



[www.mfk.co.id](http://www.mfk.co.id)



**MILLENNIAL**

We innovate  
with tech.  
We craft in Italy.  
**We make it easy.**

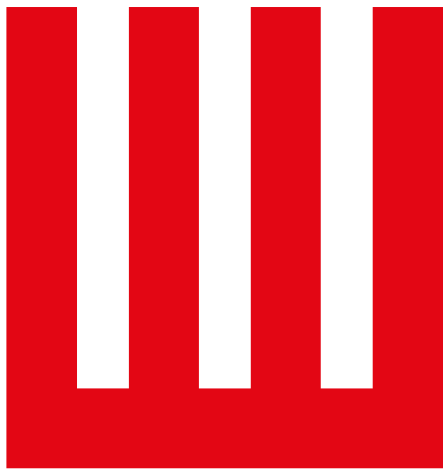

**eKa**®

**IT** I prodotti presentati in questo catalogo possono essere soggetti, senza preavviso e senza responsabilità per Tecnoeka Srl, a modifiche tecniche e di design funzionali al miglioramento degli stessi senza pregiudicare le caratteristiche essenziali.









**EN** Products presented in this catalog may be subject, without notice and without responsibility for Tecnoeka Srl, to technical and design changes aimed at their improvement without compromising the essential characteristics.



**We make it easy.**

# Indice

# Index

About Tecnoeka			Pag. 4
<b>About MILLENNIAL</b>			Pag. 6
Ogni codice ti racconta una storia Each code tells you a story			Pag. 8
Design			Pag. 10
Eka Cloud			Pag. 11
Eka Warranty			Pag. 11
Airflowlogic™			Pag. 12
Humilogic™			Pag. 14
Drylogic™			Pag. 16
Sistema di lavaggio Washing system			Pag. 18
<b>Plus MILLENNIAL TOUCH SCREEN</b>			Pag. 19
MILLENNIAL TOUCH SCREEN			Pag. 20
MILLENNIAL BLACK MASK			Pag. 22
MILLENNIAL SMART			Pag. 24
<b>Cooking</b>	Forni elettrici e gas Electric and gas ovens		Pag. 26
<b>MKF 511</b>	Forno combinato convezione vapore 5 teglie 1/1 GN Combi oven 5 trays 1/1 GN		Pag. 28
<b>MKF 711</b>	Forno combinato convezione vapore 7 teglie 1/1 GN Combi oven 7 trays 1/1 GN		Pag. 30
<b>MKF 1111</b>	Forno combinato convezione vapore 11 teglie 1/1 GN Combi oven 11 trays 1/1 GN		Pag. 32
<b>MKF 2011</b>	Forno combinato convezione vapore 20 teglie 1/1 GN Combi oven 20 trays 1/1 GN		Pag. 34
<b>MKF 621</b>	Forno combinato convezione vapore 6 teglie 2/1 GN Combi oven 6 trays 2/1 GN		Pag. 36
<b>MKF 1021</b>	Forno combinato convezione vapore 10 teglie 2/1 GN Combi oven 10 trays 2/1 GN		Pag. 38
<b>MKF 623 C</b>	Forno combinato convezione vapore 6 teglie 2/3 GN COMPATTO COMPACT combi oven 6 trays 2/3 GN		Pag. 40

<b>MKF 611 C</b>	Forno combinato convezione vapore 6 teglie 1/1 GN COMPATTO COMPACT combi oven 6 trays 1/1 GN	⚡	Pag. 42
<b>MKF 1011 C</b>	Forno combinato convezione vapore 10 teglie 1/1 GN COMPATTO COMPACT combi oven 10 trays 1/1 GN	⚡	Pag. 44
<b>Mantenitori Holding cabinets</b>	Mantenitori elettrici per forni Electric holding cabinets for ovens	⚡	Pag. 46
<b>MKM 1211</b>	Mantenitore elettrico per forni 5, 7 e 11 teglie BM e TS, comandato dal forno Electric holding cabinet for 5, 7 e 11 trays ovens BM e TS, controlled by the oven	⚡	Pag. 47
<b>Cappe Condensation hoods</b>	Cappe elettriche di aspirazione a condensazione per forni Electric condensation hood for ovens	⚡	Pag. 48
<b>MKKC 5 S</b>	Cappa elettrica di aspirazione a condensazione per forni 5 teglie S Electric condensation hood for 5 trays ovens S	⚡	Pag. 49
<b>MKKC 5</b>	Cappa elettrica di aspirazione a condensazione per forni 5 teglie BM e TS, comandata dal forno Electric condensation hood for 5 trays BM and TS ovens, controlled by the oven	⚡	Pag. 49
<b>MKKC 711 S</b>	Cappa elettrica di aspirazione a condensazione per forni 7 e 11 teglie S Electric condensation hood for 7 and 11 trays ovens S	⚡	Pag. 50
<b>MKKC 711</b>	Cappa elettrica di aspirazione a condensazione per forni 7 e 11 teglie BM e TS, comandata dal forno Electric condensation hood for 7 and 11 trays BM and TS ovens, controlled by the oven	⚡	Pag. 50
<b>MKKC 1620 S</b>	Cappa elettrica di aspirazione a condensazione per forni 16 e 20 teglie S Electric condensation hood for 16 and 20 trays ovens S	⚡	Pag. 51
<b>MKKC 1620</b>	Cappa elettrica di aspirazione a condensazione per forni 16 e 20 teglie BM e TS, comandata dal forno Electric condensation hood for 16 and 20 trays BM and TS ovens, controlled by the oven	⚡	Pag. 51
<b>MKKC 610 S</b>	Cappa elettrica di aspirazione a condensazione per forni 6 e 10 teglie S Electric condensation hood for 6 and 10 trays ovens S	⚡	Pag. 52
<b>MKKC 610</b>	Cappa elettrica di aspirazione a condensazione per forni 6 e 10 teglie BM e TS, comandata dal forno Electric condensation hood for 6 and 10 trays BM and TS ovens, controlled by the oven	⚡	Pag. 52
<b>MKKC 623 C</b>	Cappa elettrica di aspirazione a condensazione per forni 6 teglie 2/3 GN COMPATTI, comandata dal forno Electric condensation hood for 6 trays 2/3 GN COMPACT ovens, controlled by the oven	⚡	Pag. 53
<b>MKKC 610 C</b>	Cappa elettrica di aspirazione a condensazione per forni 6 e 10 teglie 1/1 GN COMPATTI, comandata dal forno Electric condensation hood for 6 and 10 trays 1/1 GN COMPACT ovens, controlled by the oven	⚡	Pag. 54
<b>Starter kit teglie Trays starter kit</b>			Pag. 55
<b>Tavoli e carrelli Tables and trolleys</b>			Pag. 56
<b>Complementi Optional</b>			Pag. 58
<b>Teglie e griglie Trays and grids</b>			Pag. 62
<b>Versatilità 1/1 GN 1/1 GN Modular design</b>			Pag. 64
<b>Versatilità 2/1 GN 2/1 GN Modular design</b>			Pag. 67
<b>Versatilità COMPATTI COMPACT Modular design</b>			Pag. 68
<b>Comparativo compatibilità Comparative of compatibility</b>			Pag. 70

# About Tecnoeka

**Tecnoeka,  
dove tecnologia  
e design  
si trasformano  
in eccellenza.**

**Tecnoeka:  
transforming  
technology  
and design  
into excellence.**

**IT** Tecnoeka nasce nel 1978 nel settore degli elettrodomestici da incasso. Negli anni '90 introduce i primi forni semi-professionali, per poi dedicarsi interamente al segmento professionale con soluzioni destinate a **ristoranti, panifici e pasticcerie, centri cottura, supermercati e snack bar**: un passaggio decisivo che ha segnato l'avvio degli investimenti in tecnologie produttive e processi sempre più avanzati.

Dal trasferimento nella sede di Borgoricco (PD) nel 2013 fino alla costruzione del nuovo stabilimento nel 2025, ogni tappa della storia ha seguito un percorso coerente: **crescere a livello internazionale, consolidando il saper fare italiano** con prodotti destinati a durare e a rispondere alle sfide di una ristorazione in continuo cambiamento.

Oggi Tecnoeka è un'impresa solida ed ambiziosa. Progetti, relazioni e una rete internazionale sempre più forte ne sostengono l'espansione strategica, permettendo di continuare a costruire **soluzioni performanti ed intuitive, al servizio dei professionisti** del foodservice di oltre 100 paesi.

**EN** Founded in 1978, Tecnoeka began in the built-in appliance industry. In the 1990s, we launched our first semi-professional ovens, eventually shifting our focus entirely to professional cooking solutions for **restaurants, bakeries, pastry shops, catering centers, supermarkets, and snack bars**. This strategic pivot marked the start of major investments in advanced technologies and production processes.

From relocating to our Borgoricco headquarters in 2013 to building a new facility in 2025, every milestone reflects our commitment to **international growth and Italian excellence**.

Our products are built to last and designed to meet the evolving demands of the foodservice industry.

Today, Tecnoeka is a solid, forward-looking enterprise. With strong partnerships, global reach, and a growing network, we continue to develop high-performance, **intuitive solutions for professionals** in over 100 countries.



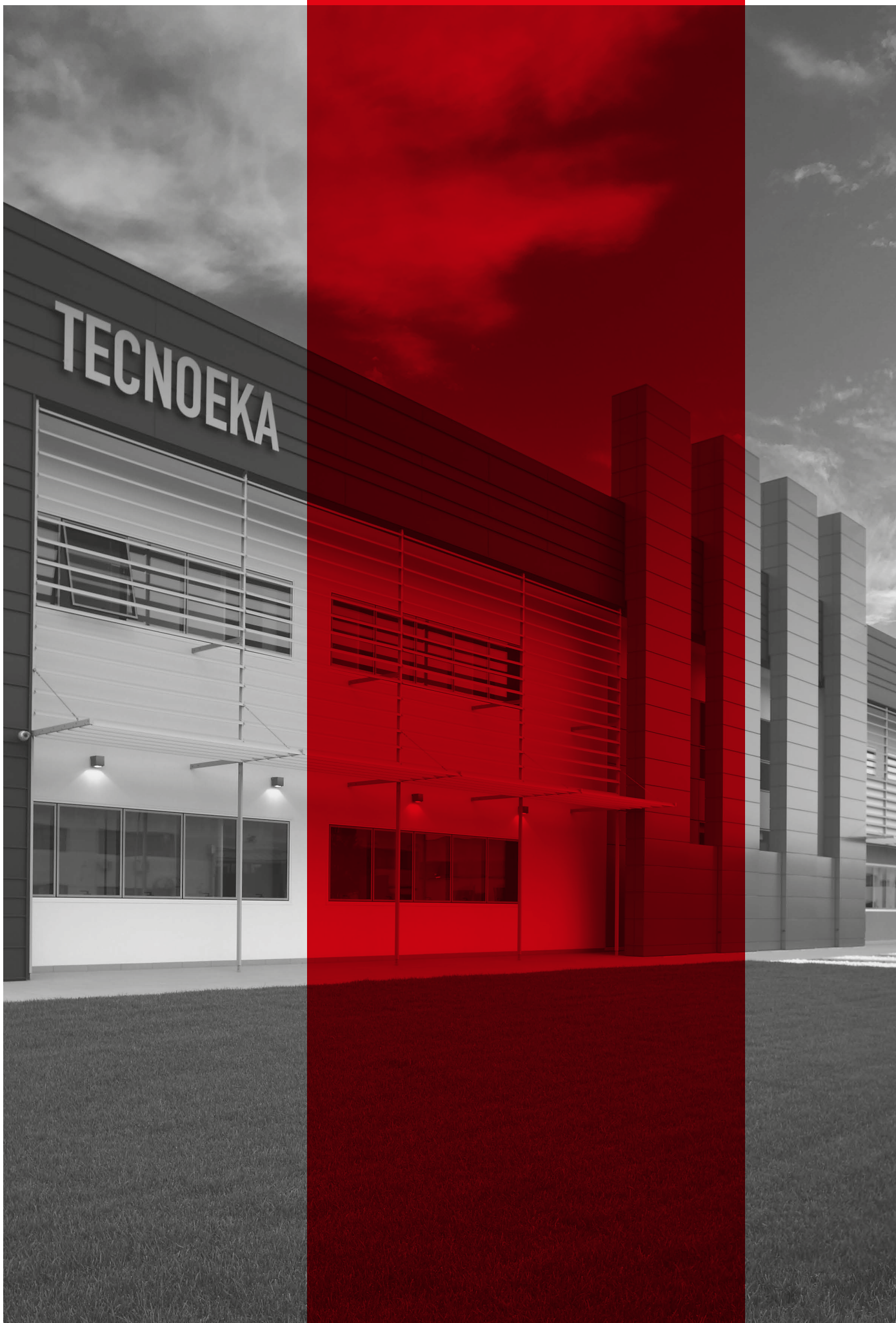

# About Millennial



Ci sono sfide che ti spingono oltre i limiti di ciò che è conosciuto,  
e superare il limite a volte può fare paura.  
Non a noi.

Il coraggio e la passione sono la firma che mettiamo dentro ad ogni progetto.

Una firma scolpita a chiare lettere sull'acciaio della linea MILLENNIAL.

Siamo orgogliosi di presentarvi la nuova generazione di forni progettata per soddisfare e stupire il professionista della ristorazione durante il suo lavoro quotidiano.

Con MILLENNIAL la qualità costruttiva incontra il futuro della ristorazione per dare alla luce qualcosa che non si era mai visto prima.

MILLENNIAL è **tecnologia**, è **design**, è **semplicità** di utilizzo.

MILLENNIAL è la differenza tra chi parla di qualità e chi conosce il significato profondo di questa parola.

La differenza tra chi percorre sempre le stesse strade e chi, come noi, porta l'innovazione nelle cucine di tutto il mondo attraverso il coraggio delle idee.

There are challenges that push you beyond the limits of what is known.

And overcoming the limit can sometimes be scary.  
Not for us.

Courage and passion are our signature in each project. A signature sculpted in clear letters on the steel of the MILLENNIAL line.

We are proud to introduce you to the new generation of ovens designed to satisfy and amaze catering professionals during their daily work.

With MILLENNIAL the constructive quality meets the future of catering to bring something to light that has never been seen before.

MILLENNIAL is **technology**, it's **design** and it's **easy** to use.

MILLENNIAL is the difference between those who speak of quality and those who know the deep meaning of this word.

The difference between those who always walk the same streets and those who like us, bring innovation to kitchens around the world through courageous ideas.

Ogni codice  
ti racconta  
una storia  
Each code  
tells you  
a story

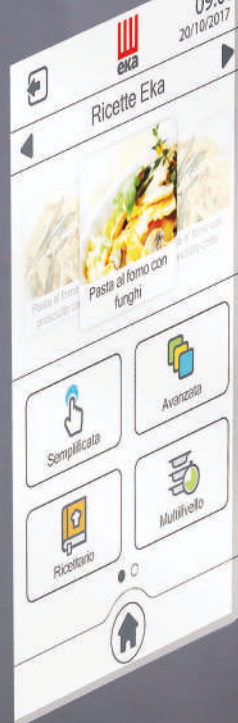

# Ogni codice ti racconta una storia

## Each code tells you a story

# MKF 6 11 V CTS P

### Famiglia Family

E Evolution Next  
M Millennial

### Marchio Brand

K Eka

### Prodotto Product

F forno/oven  
FD forno deck/deck oven  
C cucina/cooker  
P piano di cottura da appoggio  
counterop cooking plan  
KC cappa a condensazione/condensation hood  
LM lievitatore e mantentore/proofer and holding cabinet  
L lievitatore/proofer  
M mantentore/ holding cabinet  
CR carrello/trolley  
T tavolo/table  
TS tavolo con supporti/table with supports  
TR tavolo con ruote/table with wheels  
TRS tavolo con ruote e supporti/table with wheels and supports  
TSD tavolo con supporti deck/table with supports deck  
TPL tavolo polla/closet  
S kit sovrapposizione forni/kit for overlapping ovens  
ST kit sovrapposizione tavoli/kit overlapping tables  
SST kit sovrapposizione forni con supporti teglie  
kit for overlapping ovens with trays supports  
SCMU/A sonda al cuore multipunto/multi-point core probe  
SCMO sonda al cuore monopunto/single-point core probe  
SCSV sonda al cuore sottovuoto/vacuum cooking core probe  
SSC/A supporto sonda al cuore/support for core probe  
AF affumicatore/smoker  
CG concentratore grasso/fat concentrator  
FCA filtro carboni attivi/activated carbon filter  
RCA ricarica carboni attivi/activated carbon  
BZ buzzer  
WT sistema di lavaggio automatico/automatic washing system  
DET detergente e brillantante LT. 10/detergent and rinse aid LT. 10  
DETS detergente e brillantante LT. 5/detergent and rinse aid LT. 5  
KR kit ruote/set of whells  
KD kit doccia/spray kit  
CA cartuccia filtrante per trattamento acqua potabile  
filter for water optimisation  
KPI kit prima installazione TS/first installation kit TS  
KPIC kit prima installazione TS (compact)  
first installation kit (compact)  
KPI-BMS kit prima installazione BM e S/first installation kit BM and S  
KPIC-BM kit prima installazione BM (compact)  
first installation kit BM (compact)  
CKIT kit cappa Millennial BM e TS  
Millennial condensation hood kit BM e TS  
CSKIT kit cappa Millennial S/Millennial condensation hood kit S  
EKA CLOUD Connessione al portale Eka Cloud  
Connection to the Eka Cloud

### Caratteristiche Linea Line Features

P pratico/practical

### Linea Line

S smart  
BM black mask  
TS touch screen

### Linea forno Oven line

C compact  
(larghezza 500 mm)  
(width 500 mm)

### Caratteristiche Features

D double  
(per sovrapposizione forni)  
(for overlapping ovens)  
V boiler  
G gas  
2 con 2 motori  
with 2 motors  
U umidificazione a pulsante  
humidification by a button  
UD vapore diretto  
direct steam  
.3 aumento di potenza  
power increasing  
GRILL resistenza grill  
grill heating element  
M multifunzione  
multifunction  
AL apertura laterale  
side opening  
R ruote  
wheels  
IX acciaio  
stainless steel  
N Next  
NT Next Touch

### Tipologia di teglia Tray dimension

11 1/1 GN  
12 1/2 GN (325 x 265 mm)  
21 2/1 GN  
23 2/3 GN (354 x 325 mm)  
23 429 x 345 mm (EKF 423 N)  
64 600 x 400 mm

### Dimensioni esterne External dimensions

96 900 x 600 mm  
(cucine/cookers)

### Numero teglie Number of trays

3 tre teglie/three trays  
4 quattro teglie/four trays  
5 cinque teglie/five trays  
6 sei teglie/six trays  
7 sette teglie/seven trays  
10 dieci teglie/ten trays  
11 undici teglie/eleven trays  
12 dodici teglie/twelve trays  
16 sedici teglie/sixteen trays  
20 venti teglie/twenty trays  
1T uno teglia deck/one tray deck  
2T due teglie deck/two trays deck

# Design



Design minimal ed elegante per un forno professionale che aggrega funzionalità ed innovazioni tecnologiche che vanno sempre nella direzione della miglior qualità del lavoro nelle cucine.

Minimal and elegant design for a professional oven that combines functionality and technological innovations, aspects that always go towards the best quality of kitchen works.

# Eka Cloud



**EKA CLOUD, il nuovo portale** di Tecnoeka che ti permette di monitorare tutti i tuoi forni MILLENNIAL TOUCH SCREEN.

Puoi monitorare:

**EKA CLOUD, the new Tecnoeka portal** that allows you to monitor all your MILLENNIAL TOUCH SCREEN ovens.

You can monitor:

Forni connessi Connected ovens	Illimitati Unlimited
Stato del forno Oven Status	Sì Yes
Stato porta Port Status	Porta aperta o chiusa Open or closed door
Parametri impostati Set parameters	Sì Yes
Parametri grafici Graphics parameters	Sì Yes
Temperatura del forno Oven Temperature	Sì Yes
Temperatura della sonda al cuore Core probe temperature	Sì Yes
Ricetta in uso Recipe in use	Sì Yes
Dati HACCP HACCP data	Sì Yes
Aggiornamenti Firmware Firmware updates	Sì Yes
Data ultima connessione a internet Date of last internet connection	Sì Yes
Allarmi e avvisi Alarm and warnings	Sì Yes
Pannello di controllo Control panel	Sì Yes
Storico allarmi e avvisi Alarm and warnings history	Sì Yes
Lingua Language	Italiano - Inglese Italian - English
Video - Video tutorial Video and tutorials	Sì Yes
Documentazione prodotto Product documentation	Scheda tecnica, manuale d'uso, esploso Product sheet, instruction manual, exploded view

# Eka Warranty



**Garanzia 36 mesi per forni TOUCH SCREEN e BLACK MASK con lavaggio**  
36 months warranty for TOUCH SCREEN e BLACK MASK ovens with washing

## EKA WARRANTY PLATINUM

- n° 1 ACCOUNT EKA CLOUD
- n° 1 CARTUCCIA - FILTER (MKCA)
- n° 1 KIT PRIMA INSTALLAZIONE FIRST INSTALLATION KIT (MKKPI)
- n° 3 DETERGENTE - DETERGENT (MKDET)



**Garanzia 36 mesi per forni BLACK MASK senza lavaggio**  
36 months warranty for BLACK MASK ovens without washing



## EKA WARRANTY GOLD

- ACCOUNT EKA CLOUD n° 1
- CARTUCCIA - FILTER (MKCA) n° 1
- KIT PRIMA INSTALLAZIONE FIRST INSTALLATION KIT (MKKPI) n° 1

# Airflowlogic™





Airflowlogic™ by Tecnoeka è l'innovazione tecnologica brevettata che, grazie ad un carter completamente ridisegnato e ad un profondo studio del ricircolo dell'aria all'interno del forno, permette il raggiungimento di risultati ottimali nell'uniformità di cottura in tutte le aree del forno. L'uniformità grazie a Airflowlogic™ oggi diventa una garanzia per tutti coloro che scelgono l'eccellenza, per tutti coloro che scelgono Millennial.

**Canale di aspirazione**  
Inlet ductwork

**Nuova geometria  
che unisce estetica  
e funzionalità**  
New geometry which  
combines aesthetics and  
functionality

**Uniformità di  
ventilazione all'interno  
della camera di cottura**  
Uniform airflow into  
the cooking chamber

**Configurazione sezioni  
di aspirazione sia a passo  
che a geometria variabile  
per ottimizzare i flussi  
d'aria nella camera**  
Different sizes of inlet  
ductworks in order  
to optimize the air intake  
into the cooking chamber

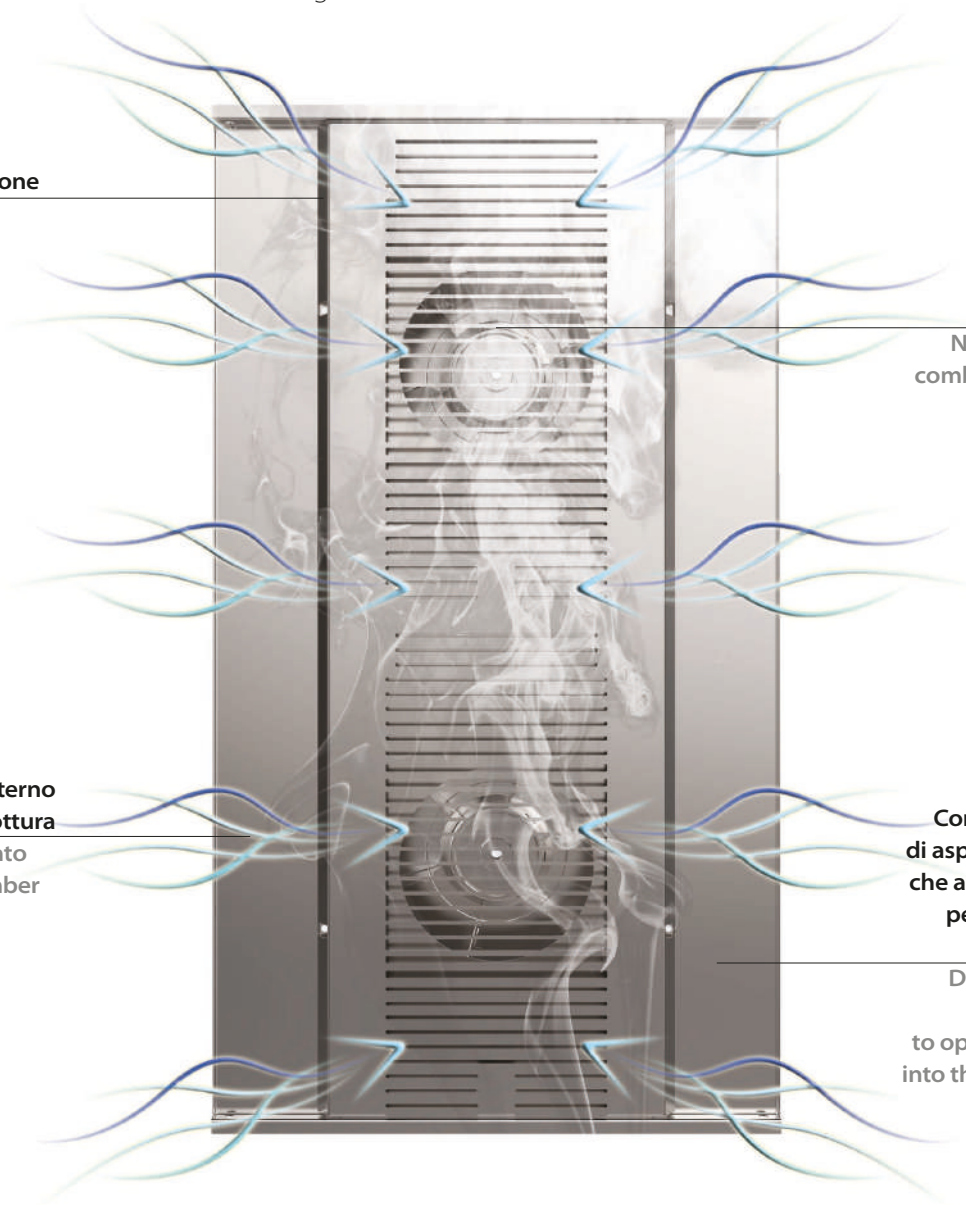

Airflowlogic™ by Tecnoeka is the patented technological innovation that, thanks to a completely redesigned fan guard and a deep study of the air recirculation inside the oven, allows the achievement of optimal cooking uniformity in all the areas of the oven. Thanks to Airflowlogic™, uniformity becomes today a guarantee for all those who choose excellence and all those who choose Millennial.

# Humilogic™





Tecnoeka presenta Humilogic™, un nuovo sistema brevettato con l'inserimento di acqua direttamente nella parte posteriore della ventola che garantisce il raggiungimento di alti livelli di umidità in camera di cottura per delle cotture a vapore di qualità e una consistente riduzione dei consumi. Humilogic™, dove il vapore incontra il sapore, mascherandosi nelle forme del cibo, esaltandone la fragranza degli aromi. Humilogic™, l'eccellenza in cucina, per tutti coloro che scelgono Millennial.

**Fori per la fuoriuscita dell'acqua**

Water output nozzles

**Scomposizione in micro particelle d'acqua tramite l'impatto con le pale della ventola**

Water contact with in-movement fan blades generates drops nebulization

**Vapore generato dal contatto delle particelle d'acqua con il calore della resistenza**

Steam generated by the contact of the water particles with the heating elements surface

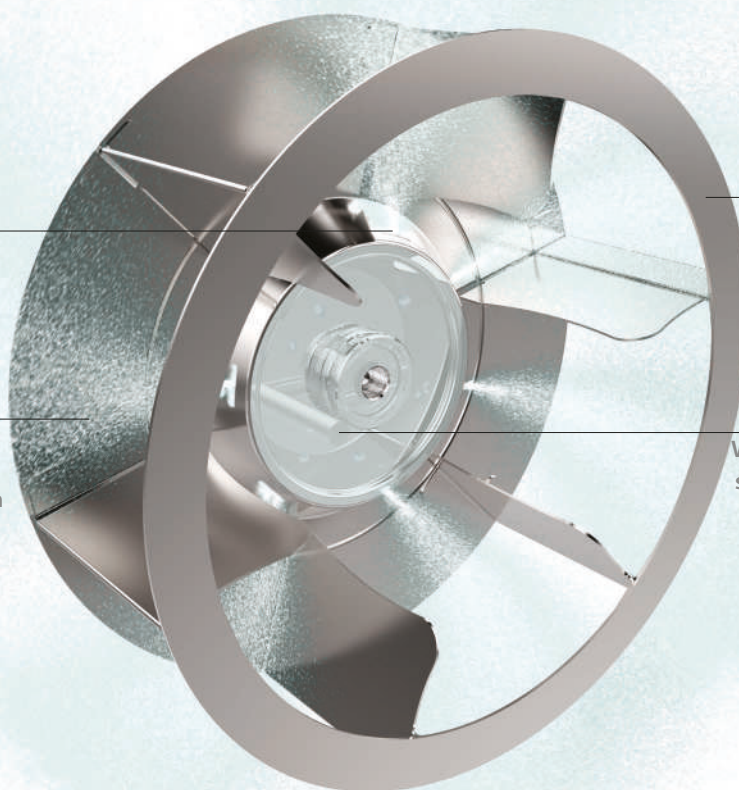

**Movimento centrifugo della ventola che permette una distribuzione uniforme dell'acqua**

The centrifugal movement of the fan allows the uniform water micro-particles distribution

**Introduzione dell'acqua per l'umidificazione dalla parte posteriore della ventola**

Water is introduced to the rear side of the fan to humidify the cooking chamber

Tecnoeka presents Humilogic™, a new-patented system with humidification on the rear that ensures high levels of moisture in the cooking chamber for quality steam cooking and a significant reduction of consumption. Humilogic™, where steam meets flavour and blends in the food thus exalting the fragrance of the aromas. Humilogic™, "Excellence in Kitchen" for all those who choose Millennial.

Drylogic™





Con il brevettato sistema di essiccazione rapida della camera di cottura Drylogic™ by Tecnoeka si ottengono cotture eccelse. La tecnologia Drylogic™ opera tramite l'introduzione nel forno di aria prelevata dall'ambiente esterno al fine di ridurre l'umidità presente all'interno della camera di cottura. Attraverso il controllo di specifici parametri predefiniti la linea Millennial ha il pieno controllo nella gestione dell'umidità.

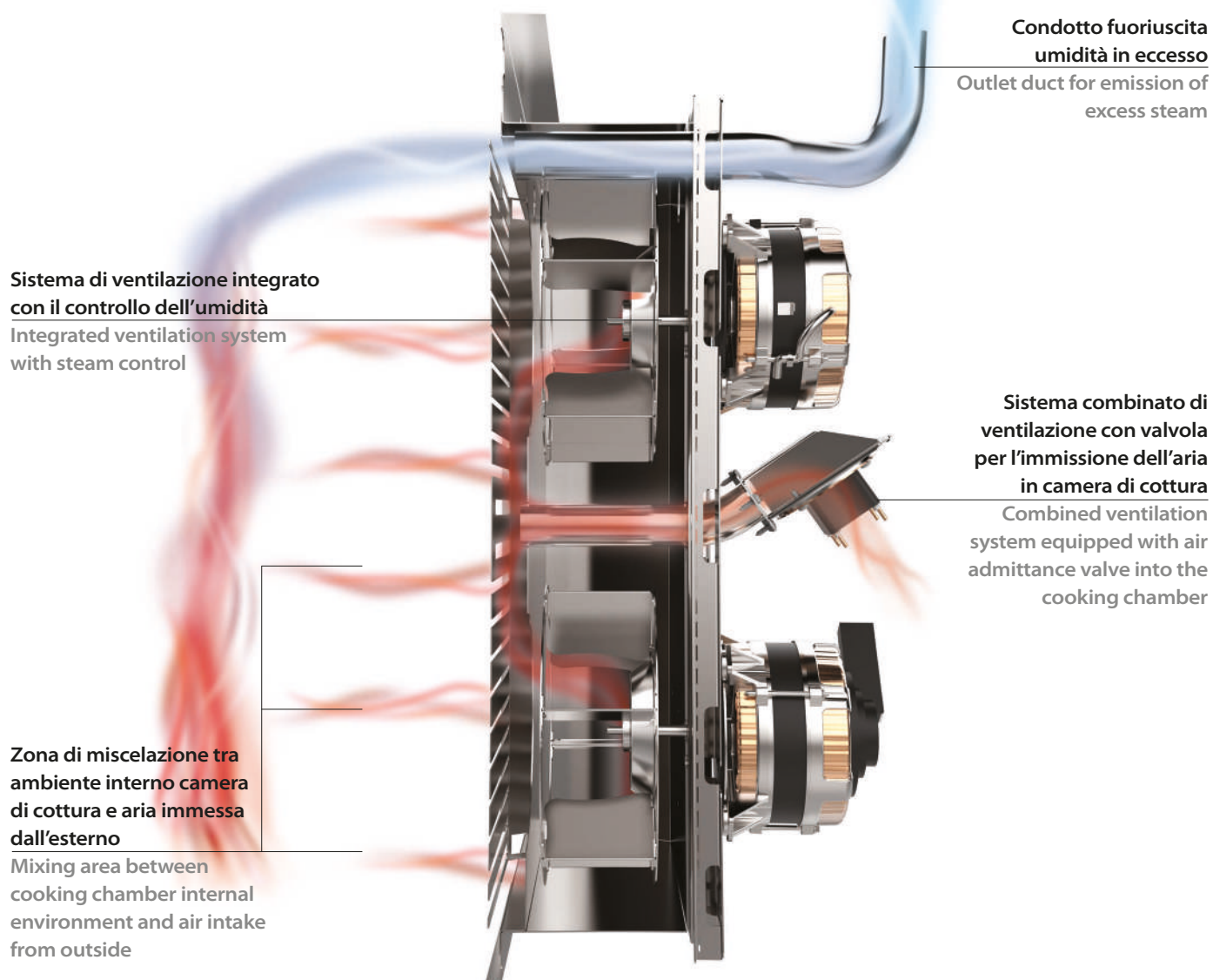

Drylogic™ by Tecnoeka. This new-patented quick-drying system in the cooking chamber allows you to reach excellent cooking. Drylogic™ technological system introduces into the oven air extracted from outside, thus reducing the moisture inside the cooking chamber. Through control of specific predefined parameters, the Millennial line has full control over managing moisture in the cooking chamber.

# Sistema di lavaggio

## Washing system

# 4

Sistemi di lavaggio  
L1 ECO, L2 NORMALE,  
L3 INTENSIVO, R RISCIAQUO  
Washing systems  
L1 ECO, L2 NORMAL,  
L3 INTENSIVE, R RINSE

Detergente e brillantante uniti  
in un unico prodotto  
Detergent and rinse aid combined  
in a single product



# - 30%

Consumi di acqua  
Water consumption

**Nuovo sistema di lavaggio di serie,  
minor ingombro, minor consumi e più efficienza**  
New washing system included,  
less bulky, less consumptions and more efficiency

# Plus

# MILLENNIAL

# TOUCH SCREEN



**30-270 °C**

Forni elettrici - Electric ovens

**30-260 °C**

Forni a gas - Gas ovens

Gestione della temperatura

Temperature management

**5**

Regolazioni della velocità di ventilazione

Speed fan regulations

Aggiornamento del firmware del forno

Oven firmware update

Gestione programma HACCP

HACCP data management

Software per gestione dell'umidità

Moisture Management Software

Gestione cotture sottovuoto e DELTA T

Vacuum cooking management and DELTA T

Cottura semistatica

Semi-static cooking mode

Aggiornamento della documentazione  
tecnica e dei manuali presenti nel forno

Updating of technical documentation and  
user manuals in the oven



**10**

Fasi per ogni ciclo di cottura

Steps for each cooking cycle

Aggiornamento dei ricettari

Recipes update

Modalità di cottura multilivello  
che permette di cucinare assieme pietanze  
con lo stesso grado di umidificazione e di  
temperatura, ma diverso tempo di cottura

Multilevel cooking mode  
allows you to cook at the same time different  
kind of foods that require the same climax  
conditions with different cooking times

**Gestione a 360° delle funzioni,  
forno collegabile in rete attraverso connessione Wi-Fi**

360 ° management of functions,  
oven connectable via Wi-Fi connection

# MILLENNIAL

## TOUCH SCREEN

**NEW**

Wi-Fi di serie  
Wi-Fi as standard



- Pannello TFT 7" capacitivo a colori 800x480 touch screen
    - **5 velocità di ventilazione**
    - Manopola con funzione scroll e push
  - Tre brevetti: **Airflowlogic™, Humilogic™, Drylogic™**
    - Lavaggio automatico integrato
    - Sonda al cuore multipunto di serie
    - Temperatura forni elettrici da 30 a 270 °C
    - forni gas da 30 a 260 °C
    - 10 fasi di cottura programmabili
  - Vapore diretto con regolazione automatica attraverso selettore touch screen (10 steps)
    - Preriscaldamento
    - Mantenimento
    - Raffreddamento rapido
  - Camera di cottura in AISI 304
  - Vetro porta ispezionabile
  - Protezione acqua: IPX3, IPX4, IPX5
    - Presa USB
    - Sistema per HACCP
  - Vaschetta raccogli condensa con scarico su porta
    - Cerniera con bloccoporta per aperture regolate a 60°, 90°, 120°, 180°
    - Partenza ritardata programmabile fino a 24 h
  - Possibilità di comandare cappa, lievitatore e mantenedor
    - Gestione rapida delle ricette di utilizzo più frequenti
    - Ricette programmabili: 500
    - 42 lingue
    - Piedini regolabili
- 
- TFT 7" capacitive 800x480 color touch screen panel
    - **5 fan speed**
    - Knob with scroll and push function
  - Three patents: **Airflowlogic™, Humilogic™, Drylogic™**
    - Automatic washing system integrated
    - Multipoint core probe
  - Temperature of electric ovens from 30 to 270 °C
  - gas ovens from 30 to 260 °C
  - 10 programmable cooking phases
  - Direct steam controlled by touch screen (10 steps)
    - Preheating
    - Holding
    - Cooldown
  - Cooking chamber in AISI 304
  - Inspectionable door glass
  - Protection against water: IPX3, IPX4, IPX5
    - USB socket
    - HACCP system
  - Condensate collection bowl, with drain on door
    - Hinge with door locking for openings adjusted at 60°, 90°, 120°, 180°
    - Delayed start programmable up to 24 h
  - Possibility to drive condensation hood and holding cabinet
    - Favorite recipes quick settings
    - Programmable recipes: 500
    - 42 languages
    - Adjustable feet

# Pannello TOUCH SCREEN

## TOUCH SCREEN panel

- 1 Ora e data - Time and date
- 2 Lista ricette - Recipes list
- 3 Cottura semplificata - Simplified cooking
- 4 Cottura avanzata - Expert cooking
- 5 Ricettario - Recipe book
- 6 Cottura multilivello - Multi-level cooking
- 7 Home
- 8 Accessori - Accessories
- 9 Raffreddamento rapido - Cooldown
- 10 Impostazioni - Settings
- 11 Servizio tecnico - After sales service



# MILLENNIAL

## BLACK MASK

**NEW**

Wi-Fi di serie  
Wi-Fi as standard



- Pannello 7" black mask electronic control
    - **3 velocità di ventilazione**
  - Due brevetti: **Airflowlogic™, Humilologic™**
    - Semplicità d' utilizzo
  - Temperatura forni elettrici da 30 a 270 °C  
forni gas da 30 a 260 °C
    - 10 fasi di cottura programmabili
  - Vapore diretto con regolazione attraverso selettore pannello black mask (10 steps)
    - Preriscaldamento
    - Mantenimento
    - Raffreddamento rapido
  - Camera di cottura in AISI 304
    - Vetro porta ispezionabile
    - Protezione acqua: IPX3, IPX4
      - Presa USB
    - Sistema per HACCP
  - Predisposizione sonda al cuore
  - Predisposizione al lavaggio automatico
  - Vaschetta raccogli condensa con scarico su porta
    - Cerniera con bloccoporta per aperture regolate a 60°, 90°, 120°, 180°
  - Partenza ritardata programmabile fino a 24 h
  - Possibilità di comandare cappa, lievitatore e mantenedor
    - Ricette programmabili: 100
    - Piedini regolabili
- 
- 7" Black mask electronic control panel
    - **3 fan speed**
  - Two patents: **Airflowlogic™, Humilologic™**
    - Easy to use
  - Temperature of electric ovens from 30 to 270 °C  
gas ovens from 30 to 260 °C
    - 10 programmable cooking phases
      - Direct steam controlled by black mask panel (10 steps)
        - Preheating
        - Holding
        - Cooldown
    - Cooking chamber in AISI 304
      - Inspectionable door glass
    - Protection against water: IPX3, IPX4
      - USB socket
    - HACCP system
    - Core probe predisposition
    - Automatic washing system predisposition
  - Condensate collection bowl, with drain on door
    - Hinge with door locking for openings adjusted at 60°, 90°, 120°, 180°
  - Delayed start programmable up to 24 h
  - Possibility to command the holding cabinet
    - Programmable recipes: 100
    - Adjustable feet

# Pannello **BLACK MASK**

## BLACK MASK panel

- 1 Preriscaldamento - Preheating
- 2 Mantenimento - Holding
- 3 Raffreddamento rapido - Cooldown
- 4 Sistema di lavaggio - Washing system
- 5 H.A.C.C.P.
- 6 Lievitatore - Proofer
- 7 Manteneritore - Holding cabinet
- 8 Allarme cappa - Condensation hood alarm
- 9 Più - Plus
- 10 Meno - Less
- 11 ON/OFF
- 12 Start/Stop

- 13 Cestino - Delete
- 14 Partenza ritardata - Delayed start
- 15 Numero ricetta - Recipe number
- 16 Menù Eka - Eka's recipes
- 17 Menù Chef - Chef's recipes
- 18 Velocità ventole - Speed fans
- 19 Funzione ventola: normale, semistatica, 1/2 potenza  
Fan function: normal, semi-static, 1/2 power
- 20 Sonda al cuore - Core probe
- 21  $\Delta T$
- 22 Temperatura sonda - Core temperature
- 23 Vapore - Steam
- 24 Temperatura - Temperature
- 25 USB
- 26 Tempo di cottura - Time of cooking
- 27 Fase di cottura - Cooking step
- 28 Ora e data - Time and date

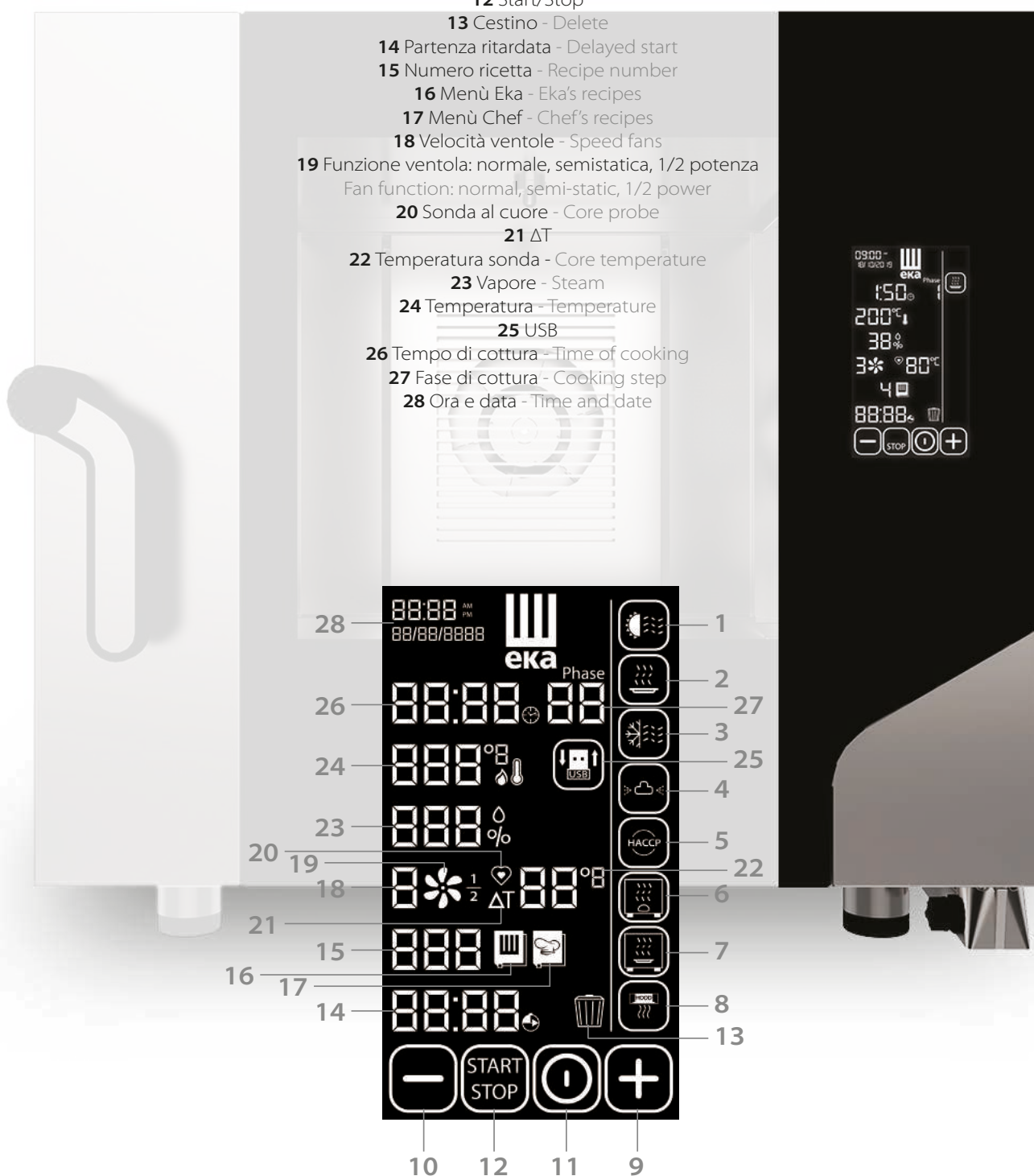

# MILLENNIAL SMART



- Pannello elettromeccanico
  - Singola velocità di ventilazione
  - Semplicità d' utilizzo
  - Timer per cottura da 10 a 120 minuti / infinito
  - Temperatura forni elettrici da 100 a 270 °C
  - forni gas da 100 a 260 °C
  - Vapore diretto con regolazione attraverso selettore a manopola (5 steps)
  - Camera di cottura in AISI 304
  - Vetro porta ispezionabile
  - Protezione acqua: IPX3, IPX4
  - Predisposizione al lavaggio manuale
  - Certificazione CB
  - Vaschetta raccogli condensa con scarico su porta
  - Cerniera con bloccoporta per aperture regolate a 60°, 90°, 120°, 180°
  - Piedini regolabili
- 
- Electromechanic panel
  - Single fan speed
  - Easy to use
  - Timer for cooking from 10 to 120 minutes / infinity
  - Temperature of electric ovens from 100 to 270 °C
  - gas ovens from 100 to 260 °C
  - Direct steam controlled by knob (5 steps)
  - Cooking chamber in AISI 304
  - Inspectable door glass
  - Protection against water: IPX3, IPX4
  - Manual washing predisposition
  - CB certification
  - Condensate collection bowl, with drain on door
  - Hinge with door locking for openings adjusted at 60°, 90°, 120°, 180°
  - Adjustable feet

# Pannello **SMART**

## SMART panel

- 1 Tempo - Time
- 2 Temperatura - Temperature
- 3 Vapore - Steam







M I L L E N N I A L  
**Cooking**



# MKF 511

Forno combinato convezione  
vapore 5 teglie 1/1 GN  
Combi oven 5 trays 1/1 GN

## SMART

### MKF 511 S



Elettrico  
Electricity ⚡

## BLACK MASK

### MKF 511 BM



Elettrico  
Electricity ⚡

Alimentazione  
Power

Numero pasti  
Number of meals

75 - 100

75 - 100

Numero teglie  
Number of trays

5

5

Dimensioni teglia  
Tray dimension

1/1 GN

1/1 GN

Passo guide  
Rack rails distance

68 mm

68 mm

Temperatura  
Temperature

100 - 270 °C

30 - 270 °C

Potenza - Portata termica  
Power supply - Thermal supply

7,8 kW

7,8 kW

Voltaggio  
Voltage

AC 380/400 3N

AC 380/400 3N

Frequenza  
Frequency

50 Hz (60 su richiesta)  
50 Hz (60 on demand)

50/60 Hz

Pannello comandi  
Control panel

Elettromeccanico  
Electromechanic

Black mask  
electronic control

N. Programmi  
N. programs

/

100

Lavaggio automatico  
Automatic washing

/

Su richiesta  
On demand

Sonda al cuore  
Core probe

/

Su richiesta  
On demand

Dimensioni (LxPxH)  
Dimensions (WxDxH)

730 x 855 x 700 mm

730 x 849 x 700 mm

Peso  
Weight

64,8 kg

67,8 kg

Generatore di vapore  
Boiler

/

/

**TOUCH SCREEN**
**SMART**
**BLACK MASK**
**TOUCH SCREEN**
**MKF 511 TS**

 Elettrico  
Electricity ⚡

**MKF 511 G S**

Gas 🔥

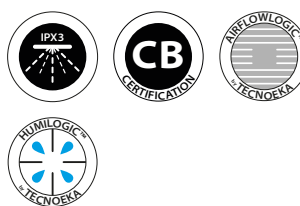
**MKF 511 G BM**

Gas 🔥

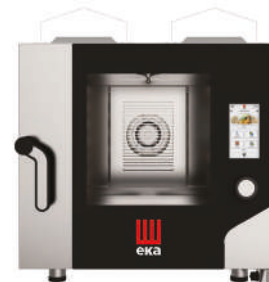
**MKF 511 GTS**

Gas 🔥

75 - 100	75 - 100	75 - 100	75 - 100
5	5	5	5
1/1 GN	1/1 GN	1/1 GN	1/1 GN
68 mm	68 mm	68 mm	68 mm
30 - 270 °C	100 - 260 °C	30 - 260 °C	30 - 260 °C
7,8 kW	9,3 kW	9,3 kW	9,3 kW
AC 380/400 3N	AC 220/230	AC 220/230	AC 220/230
50/60 Hz	50 Hz (60 su richiesta) 50 Hz (60 on demand)	50/60 Hz	50/60 Hz
Touch screen	Elettromeccanico Electromechanic	Black mask electronic control	Touch screen
500	/	100	500
Incluso Included	/	Su richiesta On demand	Incluso Included
Inclusa MKSCMU/B Included MKSCMU/B	/	Su richiesta On demand	Inclusa MKSCMU/B Included MKSCMU/B
730 x 849 x 700 mm	730 x 855 x 801 mm	730 x 849 x 801 mm	730 x 850 x 800 mm
78,4 kg	89 kg	89 kg	89 kg
/	/	/	/

# MKF 711

Forno combinato convezione  
vapore 7 teglie 1/1 GN  
Combi oven 7 trays 1/1 GN

## SMART

### MKF 711 S



## BLACK MASK

### MKF 711 BM

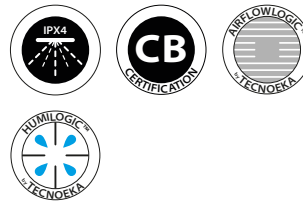

## TOUCH SCREEN

### MKF 711 TS



<b>Alimentazione</b> Power	Elettrico Electricity ⚡	Elettrico Electricity ⚡	Elettrico Electricity ⚡
<b>Numero pasti</b> Number of meals	105 - 140	105 - 140	105 - 140
<b>Numero teglie</b> Number of trays	7	7	7
<b>Dimensioni teglia</b> Tray dimension	1/1 GN	1/1 GN	1/1 GN
<b>Passo guide</b> Rack rails distance	68 mm	68 mm	68 mm
<b>Temperatura</b> Temperature	100 - 270 °C	30 - 270 °C	30 - 270 °C
<b>Potenza - Portata termica</b> Power supp.-Thermal supp.	10,4 kW	10,4 kW	11,4 kW
<b>Voltaggio</b> Voltage	AC 380/400 3N	AC 380/400 3N	AC 380/400 3N
<b>Frequenza</b> Frequency	50 Hz (60 su richiesta) 50 Hz (60 on demand)	50/60 Hz	50/60 Hz
<b>Pannello comandi</b> Control panel	Elettromeccanico Electromechanic	Black mask electronic control	Touch screen
<b>N. Programmi</b> N. programs	/	100	500
<b>Lavaggio automatico</b> Automatic washing	/	Su richiesta On demand	Incluso Included
<b>Sonda al cuore</b> Core probe	/	Su richiesta On demand	Inclusa MKSCMU/B Included MKSCMU/B
<b>Dimensioni (LxPxH)</b> Dimensions (WxDxH)	730 x 855 x 850 mm	730 x 849 x 850 mm	730 x 849 x 850 mm
<b>Peso</b> Weight	78,8 kg	82,6 kg	96 kg
<b>Generatore di vapore</b> Boiler	/	/	/

**TOUCH SCREEN**
**SMART**
**BLACK MASK**
**TOUCH SCREEN**
**MKF 711 V TS**

 Elettrico  
Electricity ⚡

**MKF 711 G S**

Gas 🔥

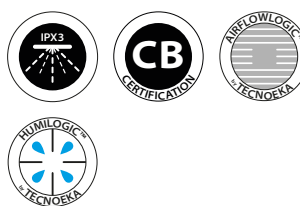
**MKF 711 G BM**

Gas 🔥

**MKF 711 G TS**

Gas 🔥

105 - 140	105 - 140	105 - 140	105 - 140
7	7	7	7
1/1 GN	1/1 GN	1/1 GN	1/1 GN
68 mm	68 mm	68 mm	68 mm
30 - 270 °C	100 - 260 °C	30 - 260 °C	30 - 260 °C
15 kW	13,5 kW	13,5 kW	13,5 kW
AC 380/400 3N	AC 220/230	AC 220/230	AC 220/230
50/60 Hz	50 Hz (60 su richiesta) 50 Hz (60 on demand)	50/60 Hz	50/60 Hz
Touch screen	Elettromeccanico Electromechanic	Black mask electronic control	Touch screen
500	/	100	500
Incluso Included	/	Su richiesta On demand	Incluso Included
Inclusa MKSCMU/B Included MKSCMU/B	/	Su richiesta On demand	Inclusa MKSCMU/B Included MKSCMU/B
730 x 849 x 850 mm	730 x 855 x 951 mm	730 x 849 x 951 mm	730 x 850 x 950 mm
102 kg	108,5 kg	108,5 kg	108,5 kg
Incluso Included Ⓢ	/	/	/

# MKF 1111

Forno combinato convezione  
vapore 11 teglie 1/1 GN  
Combi oven 11 trays 1/1 GN

## SMART

### MKF 1111 S



## BLACK MASK

### MKF 1111 BM



## TOUCH SCREEN

### MKF 1111 TS



<b>Alimentazione</b> Power	Elettrico Electricity ⚡	Elettrico Electricity ⚡	Elettrico Electricity ⚡
<b>Numero pasti</b> Number of meals	165 - 220	165 - 220	165 - 220
<b>Numero teglie</b> Number of trays	11	11	11
<b>Dimensioni teglia</b> Tray dimension	1/1 GN	1/1 GN	1/1 GN
<b>Passo guide</b> Rack rails distance	68 mm	68 mm	68 mm
<b>Temperatura</b> Temperature	100 - 270 °C	30 - 270 °C	30 - 270 °C
<b>Potenza - Portata termica</b> Power supp.-Thermal supp.	15,4 kW	15,4 kW	15,4 kW
<b>Voltaggio</b> Voltage	AC 380/400 3N	AC 380/400 3N	AC 380/400 3N
<b>Frequenza</b> Frequency	50 Hz (60 su richiesta) 50 Hz (60 on demand)	50/60 Hz	50/60 Hz
<b>Pannello comandi</b> Control panel	Elettromeccanico Electromechanic	Black mask electronic control	Touch screen
<b>N. Programmi</b> N. programs	/	100	500
<b>Lavaggio automatico</b> Automatic washing	/	Su richiesta On demand	Incluso Included
<b>Sonda al cuore</b> Core probe	/	Su richiesta On demand	Inclusa MKSCMU/B Included MKSCMU/B
<b>Dimensioni (LxPxH)</b> Dimensions (WxDxH)	730 x 855 x 1130 mm	730 x 849 x 1130 mm	730 x 849 x 1130 mm
<b>Peso</b> Weight	100,6 kg	103,6 kg	113,8 kg
<b>Generatore di vapore</b> Boiler	/	/	/

**TOUCH SCREEN**
**SMART**
**BLACK MASK**
**TOUCH SCREEN**
**MKF 1111 VTS**

 Elettrico  
Electricity ⚡

**MKF 1111 GS**

Gas 🔥

**MKF 1111 G BM**

Gas 🔥

**MKF 1111 GTS**

Gas 🔥

165 - 220	165 - 220	165 - 220	165 - 220
11	11	11	11
1/1 GN	1/1 GN	1/1 GN	1/1 GN
68 mm	68 mm	68 mm	68 mm
30 - 270 °C	100 - 260 °C	30 - 260 °C	30 - 260 °C
19 kW	17,5 kW	17,5 kW	17,5 kW
AC 380/400 3N	AC 220/230	AC 220/230	AC 220/230
50/60 Hz	50 Hz (60 su richiesta) 50 Hz (60 on demand)	50/60 Hz	50/60 Hz
Touch screen	Elettromeccanico Electromechanic	Black mask electronic control	Touch screen
500	/	100	500
Incluso Included	/	Su richiesta On demand	Incluso Included
Inclusa MKSCMU/B Included MKSCMU/B	/	Su richiesta On demand	Inclusa MKSCMU/B Included MKSCMU/B
730 x 849 x 1130 mm	730 x 855 x 1231 mm	730 x 849 x 1231 mm	730 x 850 x 1230 mm
141 kg	141 kg	141 kg	141 kg
Incluso Included Ⓜ	/	/	/

# MKF 2011

Forno combinato convezione  
vapore 20 teglie 1/1 GN  
Combi oven 20 trays 1/1 GN

## SMART

### MKF 2011 S



Elettrico  
Electricity ⚡

## BLACK MASK

### MKF 2011 BM



Elettrico  
Electricity ⚡

<b>Alimentazione</b> Power		
<b>Numero pasti</b> Number of meals	300 - 400	300 - 400
<b>Numero teglie</b> Number of trays	20	20
<b>Dimensioni teglia</b> Tray dimension	1/1 GN	1/1 GN
<b>Passo guide</b> Rack rails distance	66 mm	66 mm
<b>Temperatura</b> Temperature	100 - 270 °C	30 - 270 °C
<b>Potenza - Portata termica</b> Power supply - Thermal supply	31 kW	31 kW
<b>Voltaggio</b> Voltage	AC 380/400 3N	AC 380/400 3N
<b>Frequenza</b> Frequency	50 Hz (60 su richiesta) 50 Hz (60 on demand)	50/60 Hz
<b>Pannello comandi</b> Control panel	Elettromeccanico Electromechanic	Black mask electronic control
<b>N. Programmi</b> N. programs	/	100
<b>Lavaggio automatico</b> Automatic washing	/	Su richiesta On demand
<b>Sonda al cuore</b> Core probe	/	Su richiesta On demand
<b>Dimensioni (LxPxH)</b> Dimensions (WxDxH)	930 x 1041 x 1900 mm	930 x 1035 x 1900 mm
<b>Peso</b> Weight	247,2 kg	247,2 kg
<b>Generatore di vapore</b> Boiler	/	/

**TOUCH SCREEN**
**TOUCH SCREEN**
**BLACK MASK**
**TOUCH SCREEN**
**MKF 2011 TS**
**MKF 2011 2V TS**
**MKF 2011 G BM**
**MKF 2011 G TS**

 Elettrico  
Electricity ⚡

 Elettrico  
Electricity ⚡

Gas 🔥

Gas 🔥

# MKF 621

Forno combinato convezione  
vapore 6 teglie 2/1 GN  
Combi oven 6 trays 2/1 GN

**Alimentazione**

Power

**Numero pasti**

Number of meals

**Numero teglie**

Number of trays

**Dimensioni teglia**

Tray dimension

**Passo guide**

Rack rails distance

**Temperatura**

Temperature

**Potenza - Portata termica**

Power supply - Thermal supply

**Voltaggio**

Voltage

**Frequenza**

Frequency

**Pannello comandi**

Control panel

**N. Programmi**

N. programs

**Lavaggio automatico**

Automatic washing

**Sonda al cuore**

Core probe

**Dimensioni (LxPxH)**

Dimensions (WxDxH)

**Peso**

Weight

**Generatore di vapore**

Boiler

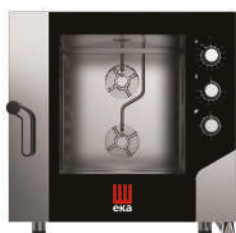

**SMART**
**BLACK MASK**
**TOUCH SCREEN**
**TOUCH SCREEN**
**MKF 621 S**

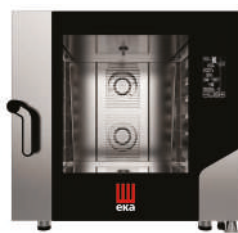
 Elettrico   
 Electricity

**MKF 621 BM**

 Elettrico   
 Electricity

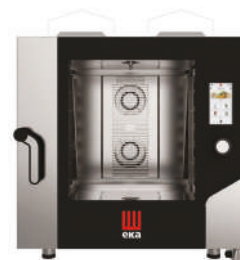
**MKF 621 TS**

 Elettrico   
 Electricity

**MKF 621 G TS**

 Gas 

180 - 270

180 - 270

180 - 270

180 - 270

6

6

6

6

2/1 GN

2/1 GN

2/1 GN

2/1 GN

80 mm

80 mm

80 mm

80 mm

100 - 270 °C

30 - 270 °C

30 - 270 °C

30 - 260 °C

18,4 kW

18,4 kW

18,4 kW

13,5 kW

AC 380/400 3N

AC 380/400 3N

AC 380/400 3N

AC 220/230

50 Hz (60 su richiesta)  
50 Hz (60 on demand)

50/60 Hz

50/60 Hz

50/60 Hz

Elettromeccanico  
ElectromechanicBlack mask  
electronic control

Touch screen

Touch screen

/

100

500

500

/

Su richiesta  
On demandIncluso  
IncludedIncluso  
Included

/

Su richiesta  
On demandInclusa MKSCMU/B  
Included MKSCMU/BInclusa MKSCMU/B  
Included MKSCMU/B

850 x 1041 x 850 mm

850 x 1035 x 850 mm

850 x 1035 x 850 mm

850 x 1035 x 950 mm

108,2 kg

108,2 kg

108,2 kg

120 kg

/

/

/

/

# MKF 1021

Forno combinato convezione  
vapore 10 teglie 2/1 GN  
Combi oven 10 trays 2/1 GN

**Alimentazione**

Power

---

**Numero pasti**

Number of meals

---

**Numero teglie**

Number of trays

---

**Dimensioni teglia**

Tray dimension

---

**Passo guide**

Rack rails distance

---

**Temperatura**

Temperature

---

**Potenza - Portata termica**

Power supply - Thermal supply

---

**Voltaggio**

Voltage

---

**Frequenza**

Frequency

---

**Pannello comandi**

Control panel

---

**N. Programmi**

N. programs

---

**Lavaggio automatico**

Automatic washing

---

**Sonda al cuore**

Core probe

---

**Dimensioni (LxPxH)**

Dimensions (WxDxH)

---

**Peso**

Weight

---

**Generatore di vapore**

Boiler

---



**SMART**
**BLACK MASK**
**TOUCH SCREEN**
**TOUCH SCREEN**
**MKF 1021 S**

 Elettrico   
 Electricity

**MKF 1021 BM**

 Elettrico   
 Electricity

**MKF 1021 TS**

 Elettrico   
 Electricity

**MKF 1021 G TS**

Gas

300 - 450	300 - 450	300 - 450	300 - 450
10	10	10	10
2/1 GN	2/1 GN	2/1 GN	2/1 GN
80 mm	80 mm	80 mm	80 mm
100 - 270 °C	30 - 270 °C	30 - 270 °C	30 - 260 °C
27,5 kW	27,5 kW	27,5 kW	18 kW
AC 380/400 3N	AC 380/400 3N	AC 380/400 3N	AC 220/230
50 Hz (60 su richiesta) 50 Hz (60 on demand)	50/60 Hz	50/60 Hz	50/60 Hz
Elettromeccanico Electromechanic	Black mask electronic control	Touch screen	Touch screen
/	100	500	500
/	Su richiesta On demand	Incluso Included	Incluso Included
/	Su richiesta On demand	Inclusa MKSCMU/B Included MKSCMU/B	Inclusa MKSCMU/B Included MKSCMU/B
850 x 1041 x 1130 mm	850 x 1035 x 1130 mm	850 x 1035 x 1130 mm	850 x 1035 x 1230 mm
140,4 kg	131 kg	140,4 kg	158 kg
/	/	/	/

# MKF 623 C

Forno combinato convezione

vapore 6 teglie 2/3 GN COMPATTO

COMPACT combi oven 6 trays 2/3 GN

**Alimentazione**

Power

**Numero pasti**

Number of meals

**Numero teglie**

Number of trays

**Dimensioni teglia**

Tray dimension

**Passo guide**

Rack rails distance

**Temperatura**

Temperature

**Potenza - Portata termica**

Power supply - Thermal supply

**Voltaggio**

Voltage

**Frequenza**

Frequency

**Pannello comandi**

Control panel

**N. Programmi**

N. programs

**Lavaggio automatico**

Automatic washing

**Sonda al cuore**

Core probe

**Dimensioni (LxPxH)**

Dimensions (WxDxH)

**Peso**

Weight

**Generatore di vapore**

Boiler

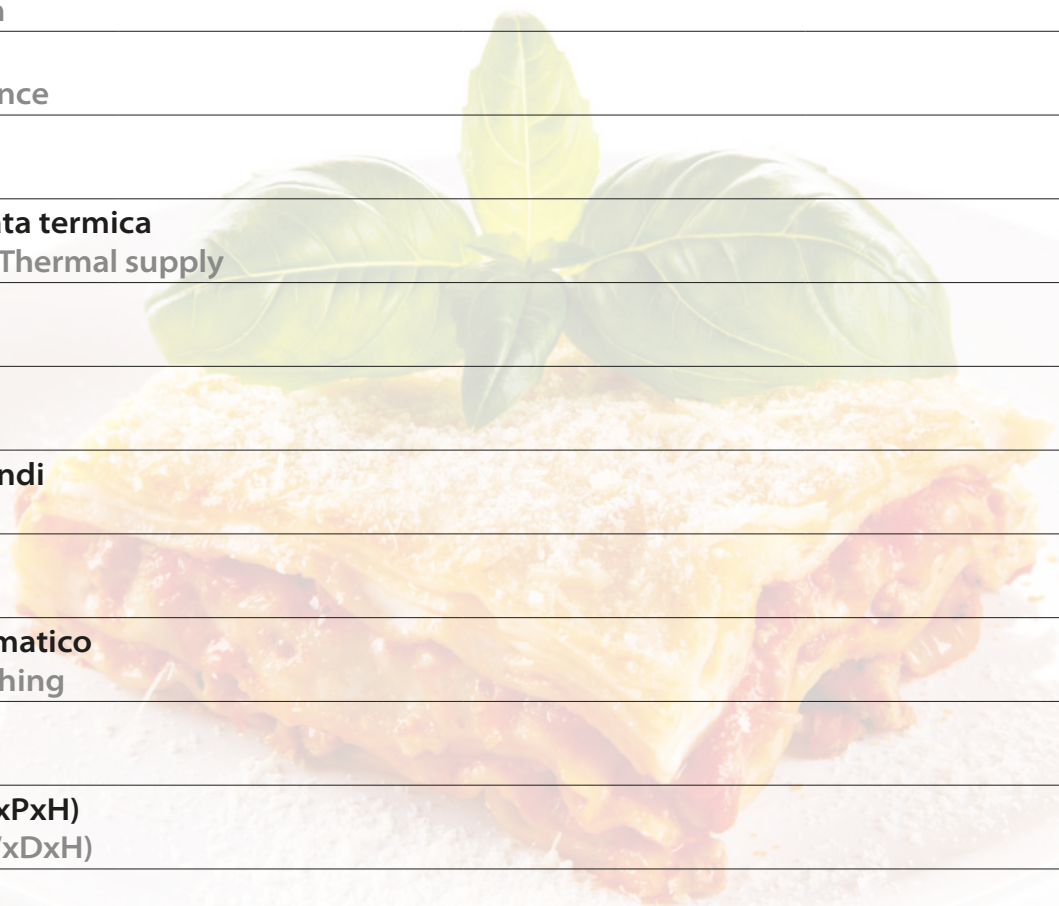

## BLACK MASK COMPACT

## TOUCH SCREEN COMPACT

### MKF 623 C BM

### MKF 623 C TS



Elettrico   
Electricity

Elettrico   
Electricity

# MKF 611 C

Forno combinato convezione

vapore 6 teglie 1/1 GN COMPATTO

COMPACT combi oven 6 trays 1/1 GN

**Alimentazione**

Power

**Numero pasti**

Number of meals

**Numero teglie**

Number of trays

**Dimensioni teglia**

Tray dimension

**Passo guide**

Rack rails distance

**Temperatura**

Temperature

**Potenza - Portata termica**

Power supply - Thermal supply

**Voltaggio**

Voltage

**Frequenza**

Frequency

**Pannello comandi**

Control panel

**N. Programmi**

N. programs

**Lavaggio automatico**

Automatic washing

**Sonda al cuore**

Core probe

**Dimensioni (LxPxH)**

Dimensions (WxDxH)

**Peso**

Weight

**Generatore di vapore**

Boiler

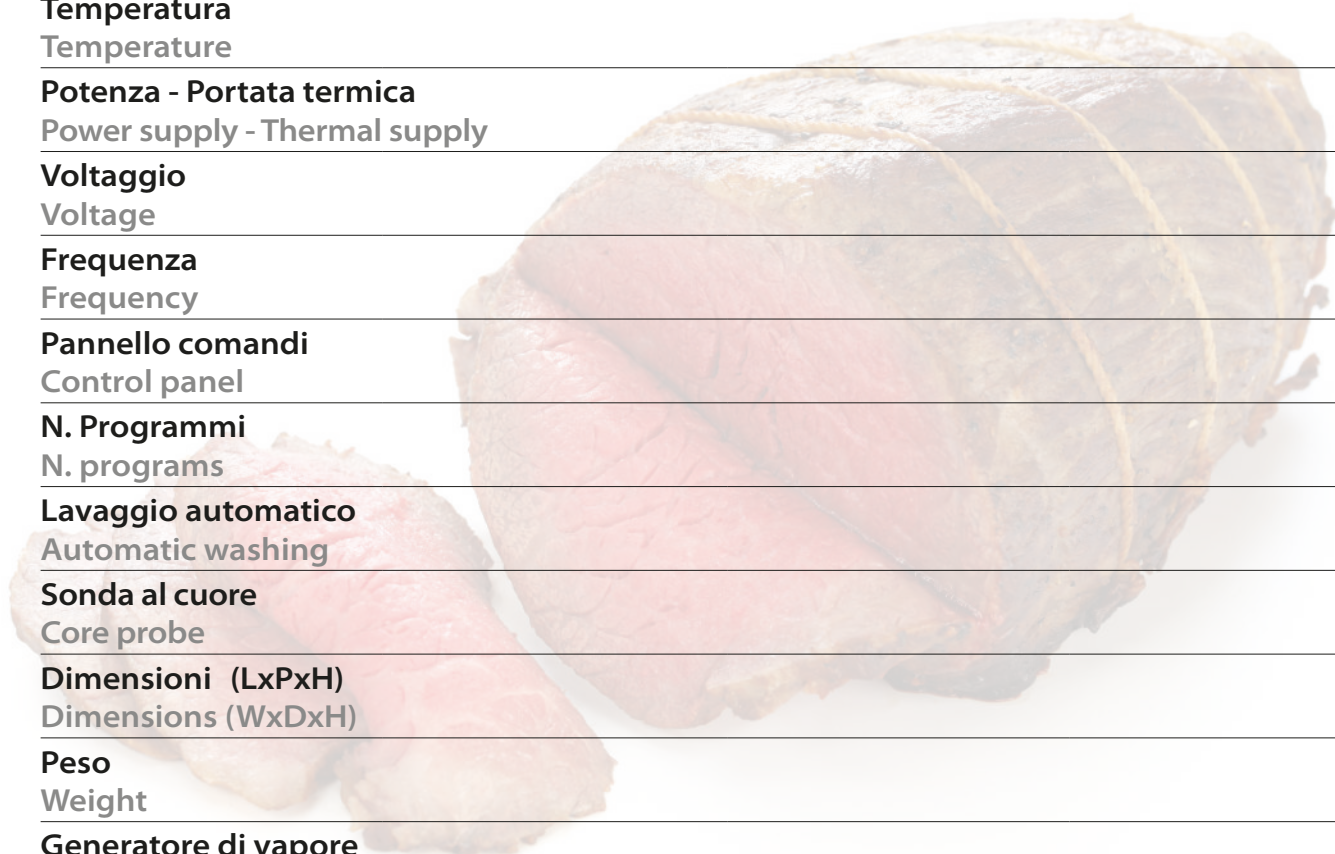

## BLACK MASK COMPACT

## TOUCH SCREEN COMPACT

## TOUCH SCREEN COMPACT

MKF 611 C BM

MKF 611 C TS

MKF 611 V C TS

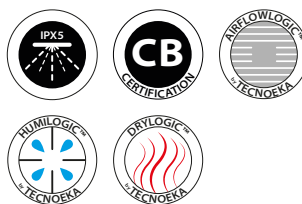

Elettrico Electricity

Elettrico Electricity

Elettrico Electricity

90 - 120

90 - 120

90 - 120

6

6

6

1/1 GN

1/1 GN

1/1 GN

68 mm

68 mm

68 mm

30 - 270 °C

30 - 270 °C

30 - 270 °C

7,8 kW

7,8 kW

11,4 kW

AC 380/400 3N

AC 380/400 3N

AC 380/400 3N

50/60 Hz

50/60 Hz

50/60 Hz

Black mask  
electronic control

Touch screen

Touch screen

100

500

500

Incluso  
Included

Incluso  
Included

Incluso  
Included

Inclusa EKSCS  
Included EKSCS

Inclusa MKSCMU/B  
Included MKSCMU/B

Inclusa MKSCMU/B  
Included MKSCMU/B

500 x 930 x 700 mm  
COMPACT

500 x 930 x 700 mm  
COMPACT

500 x 930 x 700 mm  
COMPACT

70,8 kg

70,8 kg

72,2 kg

/

/

Incluso  
Included

# MKF 1011 C

Forno combinato convezione

vapore 10 teglie 1/1 GN COMPATTO

COMPACT combi oven 10 trays 1/1 GN

**Alimentazione**

Power

**Numero pasti**

Number of meals

**Numero teglie**

Number of trays

**Dimensioni teglia**

Tray dimension

**Passo guide**

Rack rails distance

**Temperatura**

Temperature

**Potenza - Portata termica**

Power supply - Thermal supply

**Voltaggio**

Voltage

**Frequenza**

Frequency

**Pannello comandi**

Control panel

**N. Programmi**

N. programs

**Lavaggio automatico**

Automatic washing

**Sonda al cuore**

Core probe

**Dimensioni (LxPxH)**

Dimensions (WxDxH)

**Peso**

Weight

**Generatore di vapore**

Boiler



## BLACK MASK COMPACT

MKF 1011 C BM



Elettrico Electricity

## TOUCH SCREEN COMPACT

MKF 1011 C TS



Elettrico Electricity

## TOUCH SCREEN COMPACT

MKF 1011 V C TS



Elettrico Electricity

150 - 200	150 - 200	150 - 200
10	10	10
1/1 GN	1/1 GN	1/1 GN
68 mm	68 mm	68 mm
30 - 270 °C	30 - 270 °C	30 - 270 °C
15,4 kW	15,4 kW	19 kW
AC 380/400 3N	AC 380/400 3N	AC 380/400 3N
50/60 Hz	50/60 Hz	50/60 Hz
Black mask electronic control	Touch screen	Touch screen
100	500	500
Incluso Included	Incluso Included	Incluso Included
Inclusa EKSCS Included EKSCS	Inclusa MKSCMU/B Included MKSCMU/B	Inclusa MKSCMU/B Included MKSCMU/B
<b>500</b> x 930 x 970 mm COMPACT	<b>500</b> x 930 x 970 mm COMPACT	<b>500</b> x 930 x 970 mm COMPACT
95,2 kg	95,2 kg	105 kg
/	/	Incluso  Included

# Mantenitori

## Holding cabinets





# MKM 1211

**Mantenitore elettrico per forni 5, 7 e 11 teglie  
BM e TS, comandato dal forno**

**Electric holding cabinet for 5, 7 and 11 trays  
BM and TS ovens, controlled by the oven**



<b>Numero teglie</b> Number of trays	12
<b>Dimensioni teglia</b> Tray dimension	1/1 GN
<b>Passo guide</b> Rack rails distance	75 mm
<b>Temperatura</b> Temperature	65 - 85 °C
<b>Potenza</b> Power supply	1,8 kW
<b>Voltaggio</b> Voltage	AC 220/230
<b>Frequenza</b> Frequency	50/60 Hz
<b>Dimensioni (LxPxH)</b> Dimensions (WxDxH)	730 x 875 x 770 mm
<b>Peso</b> Weight	70,8 kg

# Cappe

## Condensation hoods



# MKKC 5

Cappa elettrica di aspirazione a condensazione  
per forni 5 teglie BM e TS, comandata dal forno

Electric condensation hood for 5 trays  
BM and TS ovens, controlled by the oven

Disponibile **MKKC 5 S** per forni 5 teglie S (MKF 511 S)  
**MKKC 5 S** available for 5 trays S ovens (MKF 511 S)



<b>Potenza</b> Power supply	0,6 kW
<b>Voltaggio</b> Voltage	AC 220/230
<b>Frequenza</b> Frequency	50/60 Hz
<b>Dimensioni (LxPxH)</b> Dimensions (WxDxH)	730 x 860 x 308 mm
<b>Peso</b> Weight	26 kg

Gruppo condensazione di dimensioni inferiori rispetto al modello MKKC 711  
Condensation unit smaller than the model MKKC 711

# MKKC 711

Cappa elettrica di aspirazione a condensazione  
per forni 7 e 11 teglie BM e TS, comandata dal forno

Electric condensation hood for 7 and 11 trays  
BM and TS ovens, controlled by the oven

Disponibile **MKKC 711 S** per forni 7 e 11 teglie S  
(MKF 711 S e MKF 1111 S)

**MKKC 711 S** available for 7 and 11 trays S ovens  
(MKF 711 S and MKF 1111 S)



<b>Potenza</b> Power supply	0,6 kW
<b>Voltaggio</b> Voltage	AC 220/230
<b>Frequenza</b> Frequency	50/60 Hz
<b>Dimensioni (LxPxH)</b> Dimensions (WxDxH)	730 x 860 x 308 mm
<b>Peso</b> Weight	26 kg

# MKKC 1620

**Cappa elettrica di aspirazione a condensazione per forni 16 e 20 teglie BM e TS, comandata dal forno**

**Electric condensation hood for 16 and 20 trays BM and TS ovens, controlled by the oven**

**Disponibile MKKC 1620 S per forni 16 e 20 teglie S (MKF 1664 S e MKF 2011 S)**

**MKKC 1620 S available for 16 and 20 trays S ovens (MKF 1664 S and MKF 2011 S)**



<b>Potenza</b> Power supply	0,6 kW
<b>Voltaggio</b> Voltage	AC 220/230
<b>Frequenza</b> Frequency	50/60 Hz
<b>Dimensioni (LxPxH)</b> Dimensions (WxDxH)	930 x 1045 x 308 mm
<b>Peso</b> Weight	31,4 kg

# MKKC 610

Cappa elettrica di aspirazione a condensazione  
per forni 6 e 10 teglie BM e TS, comandata dal forno

Electric condensation hood for 6 and 10 trays  
BM and TS ovens, controlled by the oven

Disponibile **MKKC 610 S** per forni 6 e 10 teglie S  
(MKF 664 S, MKF 621 S, MKF 1064 S e MKF 1021 S)

**MKKC 610 S** available for 6 and 10 trays S ovens  
(MKF 664 S, MKF 621 S, MKF 1064 S and MKF 1021 S)

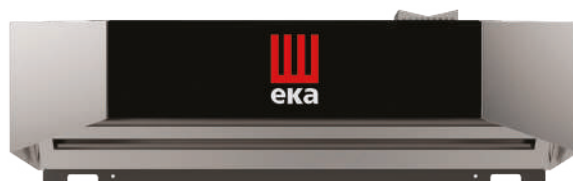

<b>Potenza</b> Power supply	0,6 kW
<b>Voltaggio</b> Voltage	AC 220/230
<b>Frequenza</b> Frequency	50/60 Hz
<b>Dimensioni (LxPxH)</b> Dimensions (WxDxH)	850 x 1045 x 308 mm
<b>Peso</b> Weight	29 kg

# MKKC 623 C

**Cappa elettrica di aspirazione a condensazione  
per forni 6 teglie 2/3 GN COMPATTI, comandata dal forno**

**Electric condensation hood for 6 trays 2/3 GN  
COMPACT ovens, controlled by the oven**



<b>Potenza</b> Power supply	0,6 kW
<b>Voltaggio</b> Voltage	AC 220/230
<b>Frequenza</b> Frequency	50/60 Hz
<b>Dimensioni (LxPxH)</b> Dimensions (WxDxH)	500 x 762 x 308 mm
<b>Peso</b> Weight	17,6 kg

# MKKC 610 C

**Cappa elettrica di aspirazione a condensazione  
per forni 6 e 10 teglie COMPATTI, comandata dal forno**

**Electric condensation hood for 6 and 10 trays**

**COMPACT ovens, controlled by the oven**



<b>Potenza</b> Power supply	0,6 kW
<b>Voltaggio</b> Voltage	AC 220/230
<b>Frequenza</b> Frequency	50/60 Hz
<b>Dimensioni (LxPxH)</b> Dimensions (WxDxH)	500 x 942 x 308 mm
<b>Peso</b> Weight	19 kg

# Starter kit teglie

## Trays starter kit

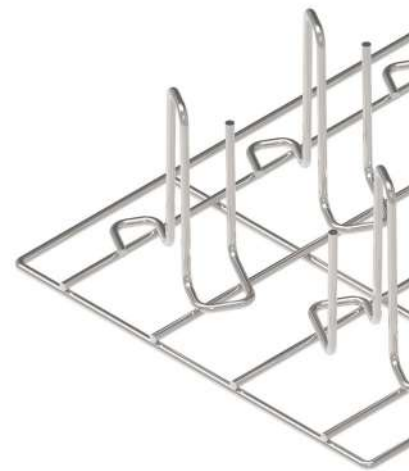

### KIT LOVE COOKING

N° pezzi per kit N° of pieces per kit	Codice Code	Descrizione prodotto Product description
2	<b>KT9G</b>	Teglia in AISI 304 1/1 GN (530x325x40 mm) AISI 304 1/1 GN baking tray (530x325x40 mm)
2	<b>KFT9G</b>	Teglia forata in acciaio inox AISI 304, GN 1/1 h. 40 Perforated tray in AISI 304 stainless steel, GN 1/1 h. 40
2	<b>KG9GX</b>	Griglia mod. KG9G AISI 304 1/1 GN per forni da 90 cm e cucine Grid mod. KG9G AISI 304 1/1 GN for 90 cm ovens and cookers
1	<b>KPGR11A</b>	Piastra rigata con rivestimento antiaderente 1/1 GN Ribbed griddle with 1/1 GN non-stick coating
1	<b>MKT11RG</b>	Teglia 1/1 GN in AISI 304 raccogli grasso per griglia polli h. 25 1/1 GN AISI 304 grease-collecting tray for chicken grilling, h. 25
1	<b>EKTF11</b>	Teglia forata in AISI 304 1/1 GN per cottura nugget (533x330x38,5) Perforated tray in AISI 304 1/1 GN for nugget cooking (533x330x38.5)
1	<b>EKTF11PT/A</b>	Teglia teflonata in alluminio forato spessore 15/10 GN 1/1 h. 20 con alette su tutti i quattro lati Teflon-coated perforated aluminum tray, thickness 15/10 GN 1/1 h. 20 with fins on all four sides
1	<b>KGP</b>	Griglia 1/1 GN inox 304 per cottura verticale polli capacità 8 pz (530x325x150mm) 1/1 GN 304 stainless steel grill for vertical cooking of chickens, capacity of 8 pieces (530x325x150mm)



# Tavoli e carrelli

## Tables and trolleys



### MKTS 11

Tavolo fisso in AISI 430 con supporti per forni 5 - 7 - 11 teglie,  
per MKF 511 con kit sovrapposizione forni  
con supporto teglie MKSST 511;  
per MKF 711 con kit sovrapposizione forni MKST 711;  
per MKF 1111 con kit sovrapposizione forni MKS 11

AISI 430 fixed table with supports for ovens 5 - 7- 11 trays,  
for MKF 511 with kit for overlapping ovens  
with tray supports MKSST 511;  
for MKF 711 with kit for overlapping ovens MKST 711;  
for MKF 1111 with kit for overlapping ovens MKS 11  
730 x 600 x 770 mm  
per mod - for mod: MKF 511, MKF 711, MKF 1111



### MKT 11 D

Tavolo fisso in AISI 430 per forni 5 - 7 - 11 teglie  
(per sovrapposizione forni),  
per MKF 511 con kit sovrapposizione forni  
con supporto teglie MKSST 511;  
per MKF 711 con kit sovrapposizione forni MKS 11;  
per MKF 1111 con kit sovrapposizione forni MKS 11

AISI 430 fixed table for ovens 5 - 7- 11 trays (for overlapping ovens),  
for MKF 511 with kit for overlapping ovens  
with tray supports MKSST 511;  
for MKF 711 with kit for overlapping ovens MKS 11;  
for MKF 1111 with kit for overlapping ovens MKS 11  
730 x 600 x 220 mm  
per mod - for mod: MKF 511, MKF 711, MKF 1111



### MKTS 21

Tavolo fisso in AISI 430 con supporti per forni 6 - 10 teglie 2/1 GN,  
per MKF 621 con kit sovrapposizione forni MKST 664;  
per MKF 1021 con kit sovrapposizione forni MKS 64

AISI 430 fixed table with supports for ovens 6- 10 trays 2/1 GN,  
for MKF 621 with kit for overlapping oven MKST 664;  
for MKF 1021 with kit for overlapping ovens MKS 64  
850 x 787 x 770 mm  
per mod - for mod: MKF 621, MKF 1021



### MKT 64 D

Tavolo fisso in AISI 430 per forni 4 - 6 - 10 teglie  
(per sovrapposizione forni),  
per MKF 464 con kit sovrapposizione forni  
con supporti teglie MKSST 464;  
per MKF 664 e MKF 621 con kit sovrapposizione forni MKS 64;  
per MKF 1064 e MKF 1021 con kit sovrapposizione forni MKS 64

AISI 430 fixed table, for ovens 4 - 6- 10 trays  
(for overlapping ovens),  
for MKF 464 with kit for overlapping ovens  
with tray supports MKSST 464;  
for MKF 664 and MKF 621 with kit for overlapping oven MKS 64;  
for MKF 1064 and MKF 1021 with kit for overlapping oven MKS 64  
850 x 787 x 220 mm  
per mod - for mod: MKF 464, MKF 664, MKF 1064, MKF 621, MKF 1021



## MKTS 623 C

Tavolo fisso in AISI 430 con supporti, per MKF 623 C con kit sovrapposizione forni con supporto teglie MKSST 623 C

AISI 430 fixed table with supports, for MKF 623 C with kit for overlapping ovens with tray supports MKSST 623 C  
500 x 556 x 770 mm  
per mod - for mod: MKF 623 C



## MKT 623 D C

Tavolo fisso in AISI 430 (per sovrapposizione forni), per MKF 623 C con kit sovrapposizione forni MKS 623 C

AISI 430 fixed table (for overlapping ovens), for MKF 623 C with kit for overlapping ovens MKS 623 C  
500 x 556 x 220 mm  
per mod - for mod: MKF 623 C



## MKTS 11 C

Tavolo fisso in AISI 430 con supporti per forni 6 - 10 teglie compatti, per MKF 611 C con kit sovrapposizione forni con supporto teglie MKSST 611 C; per MKF 1011 C con kit sovrapposizione forni MKS 11 C

AISI 430 fixed table with supports for compact ovens 6 - 10 trays, for MKF 611 C with kit for overlapping ovens with tray supports MKSST 611 C; for MKF 1011 C with kit for overlapping ovens MKS 11 C  
500 x 736 x 770 mm  
per mod - for mod: MKF 611 C, MKF 1011 C



## MKT 11 D C

Tavolo fisso in AISI 430 per forni 6 teglie compatti (per sovrapposizione forni), per MKF 611 C con kit sovrapposizione forni con supporto teglie MKSST 611 C

AISI 430 fixed table for compact ovens 6 trays (for overlapping ovens), for MKF 611 C with kit for overlapping ovens with tray supports MKSST 611 C  
500 x 736 x 220 mm  
per mod - for mod: MKF 611 C



## MKTPL

Tavolo polli chiuso in AISI 430 fisso con kit raccogli grasso e 2 taniche da 10 lt incluse

AISI 430 closet with kit for fat collection and 2 tanks included 10 lt  
730 x 666 x 770 mm  
per mod - for mod: MKF 711 BM, MKF 711 TS, MKF 1111 BM, MKF 1111 TS (con scarico grassi - with fat drain)



## EKCR 20 TC

Carrello estraibile in AISI 304 con impugnatura ergonomica asportabile e ruote frenanti, per forni 20 teglie











AISI 304 pull-out trolley with removable handle and braked wheels, for 20 trays ovens  
660 x 560 x 1704 mm  
per mod - for mod: MKF 2011

# Complementi

## Optionals



	<b>EKKD</b>	<p>Kit doccia completo di supporto doccia, tubo e relativa predisposizione per mod: tutti i forni millennial tranne MKF 664 SP, MKF D1T e MKF D2T</p> <p>Spray kit with support and tube for mod: all millennial ovens except MKF 664 SP, MKF D1T and MKF D2T</p>
	<b>MKSCMO</b>	<p>Sonda al cuore monopunto per mod: tutti i forni millennial TS</p> <p>Single-point core probe for mod: all TS millennial ovens</p>
	<b>MKSCMU/B</b>	<p>Sonda al cuore multipunto (3 punti) per mod: tutti i forni millennial TS</p> <p>Multi-point core probe (3 points) for mod: all TS millennial ovens</p>
	<b>MKSCSV</b>	<p>Sonda al cuore cottura "sottovuoto" per mod: tutti i forni millennial TS</p> <p>Vacuum cooking core probe for mod: all TS millennial ovens</p>
	<b>MKSSC/A</b>	<p>Supporto sonda al cuore per mod: tutti i forni millennial TS</p> <p>Support for core probe for mod: all TS millennial ovens</p>
	<b>EKSCS</b>	<p>Sonda al cuore con supporto per mod: tutti i forni millennial BM</p> <p>Core probe with support for mod: all BM millennial ovens</p>
	<b>MKAF</b>	<p>Affumicatore per mod: tutti i forni millennial</p> <p>Smoker for mod: all millennial ovens</p>
	<b>MKCG</b>	<p>Concentratore grasso in AISI 304 per mod: tutti i forni millennial 1/1 GN TS e BM</p> <p>AISI 304 Fat concentrator for mod: all TS and BM 1/1 GN millennial ovens 205 x 205 mm</p>
	<b>EKFCA</b>	<p>Filtro carboni attivi per mod: tutte le cappe millennial</p> <p>Activated carbon filter for mod: all millennial condensation hoods 364 x 315 x 258 mm</p>
	<b>RCA</b>	<p>Ricarica carboni attivi</p> <p>Activated carbon 25 kg per mod - for mod: EKFCA</p>
	<b>MKBZ</b>	<p>Buzzer potenziato per forni millennial per mod: tutti i forni millennial TS</p> <p>Boosted buzzer for millennial ovens for mod: all TS millennial ovens</p>

	<b>MKWT</b>	<p>Sistema di lavaggio automatico per mod: tutti i forni millennial BM</p> <p>Automatic washing system for mod: all BM millennial ovens</p>
	<b>MKDET</b>	<p>Detergente e brillantante per mod: tutti i forni millennial TS e BM</p> <p>Detergent and rinse aid for mod: all TS and BM millennial ovens 12 kg</p>
	<b>MKDETS</b>	<p>Detergente e brillantante per mod: tutti i forni millennial TS e BM</p> <p>Detergent and rinse aid for mod: all TS and BM millennial ovens 6 kg</p>
	<b>MKCA</b>	<p>Cartuccia filtrante per trattamento acqua potabile per tutti i forni millennial tranne MKF 664 SP</p> <p>Filter for water optimisation for all millennial ovens except MKF 664 S P</p>
	<b>MKKR</b>	<p>Kit ruote (2 ruote piroettanti con freno, 2 ruote piroettanti senza freno)</p> <p>Set of wheels (2 rotating wheels with brake, 2 rotating wheels without brake) H 110 mm</p> <p>per mod - for mod: MKTS 11, MKTS 623 C, MKTS 11 C, MKTS 64, MKTS 21</p>
	<b>MKKPI</b>	<p>Kit prima installazione per forni millennial TS, BM e S (non compatti)</p> <p>First installation kit for millennial TS, BM and S ovens (no compact ovens)</p>
	<b>MKKPIC</b>	<p>Kit prima installazione per forni millennial TS e BM compatti</p> <p>First installation kit for millennial TS and BM compact ovens</p>
	<b>MKCKIT</b>	<p>Kit cappa Millennial per forni TS e BM sovrapposti per mod: tutte le cappe dei forni millennial TS e BM tranne MKKC 1620</p> <p>Millennial condensation hood kit for overlapped ovens for mod: all condensation hoods for millennial TS e BM ovens except MKKC 1620</p>
	<b>MKCSKIT</b>	<p>Kit cappa Millennial per forni S sovrapposti per mod: tutte le cappe dei forni millennial S tranne MKKC 1620 S</p> <p>Millennial condensation hood kit for overlapped ovens for mod: all condensation hoods for millennial S ovens except MKKC 1620 S</p>
	<b>MKEV</b>	<p>Estrattore ventole per mod: tutti i forni millennial</p> <p>Fan puller for mod: all millennial ovens</p>

# Complementi

## Optionals



### MKS 11

Kit sovrapposizione forni in AISI 430 H 55 mm  
per sovrapposizione MKF 511 a MKF 511 oppure a MKF 1111;  
per sovrapposizione MKF 711 a MKF 711 oppure a MKT 11 D;  
per sovrapposizione MKF1111 a MKM 1211 o a MKT 11 D  
oppure a MKTS 11;  
per sovrapposizione MKF 1111 (con scarico grassi) a MKTPL

AISI 430 kit for overlapping ovens H 55 mm  
for overlapping MKF 511 with MKF 511 or with MKF 1111;  
for overlapping MKF 711 with MKF 711 or with MKT 11 D;  
for overlapping MKF1111 with MKM 1211 or  
MKT 11 D or with MKTS 11;  
for overlapping MKF 1111 (with fat drain) with MKTPL  
per mod - for mod: MKF 511, MKF 711, MKF 1111



### MKST 711

Kit sovrapposizione forni in AISI 430 H 180 mm  
per sovrapposizione MKF 711 a MKM 1211 oppure a MKTS 11;  
per sovrapposizione MKF 711 (con scarico grassi) a MKTPL

AISI 430 kit for overlapping ovens H 180 mm  
for overlapping MKF 711 with MKM 1211 or with MKTS 11;  
for overlapping MKF 711 (with fat drain) with MKTPL  
per mod - for mod: MKF 711



### MKSST 511

Kit sovrapposizione forni con supporti teglie in AISI 430,  
capacità 3 teglie 1/1 GN per sovrapposizione MKF 511 a MKM 1211 o  
a MKT 11 D oppure a MKTS 11

AISI 430 kit for overlapping ovens with trays supports,  
capacity of 3 trays 1/1 GN for overlapping MKF 511 with MKM 1211 or  
MKT 11 D or with a MKTS 11  
per mod - for mod: MKF 511



### MKS 64

Kit sovrapposizione forni in AISI 430 H 55 mm  
per sovrapposizione MKF 464 a MKF 464, MKF 1064  
oppure a MKF D1T;  
per sovrapposizione MKF 664 o MKF 621 a MKF 664,  
MKF 621, MKF D1T oppure a MKT 64 D;  
per sovrapposizione MKF 1064 a MKLM 1064, MKL 1064 S o  
a MKT 64 D oppure a MKTS 64;  
per sovrapposizione MKF D1T a MKTS 64, MKLM 1064  
oppure a MKL 1064 S;  
per sovrapposizione MKF D2T a MKTSD 2T;  
per sovrapposizione MKF 1021 a MKT 64 D oppure a MKTS 21

AISI 430 kit for overlapping ovens H 55 mm  
for overlapping MKF 464 with MKF 464 or with MKF 1064  
or with MKF D1T;  
for overlapping MKF 664 or MKF 621 with MKF 664,  
MKF 621, MKF D1T or with MKT 64 D;  
for overlapping MKF 1064 with MKLM 1064, MKL 1064 S,  
MKT 64 D or with MKTS 64;  
for overlapping MKF D1T with MKTS 64, MKLM 1064 or with MKL 1064 S;  
for overlapping MKF D2T with MKTSD 2T;  
for overlapping MKF 1021 with MKT 64 D or with MKTS 21  
per mod - for mod: MKF 464, MKF 664, MKF 1064,  
MKF D1T, MKF D2T, MKF 621 MKF 1021

	<b>MKST 664</b>	<p>Kit sovrapposizione forni in AISI 430 H 180 mm per sovrapposizione MKF 664 a MKLM 1064, MKL 1064 S oppure a MKTS 64; per sovrapposizione MKF 621 a MKTS 21</p> <p>AISI 430 kit for overlapping ovens H 180 mm for overlapping MKF 664 with MKLM 1064, MKL 1064 S or with MKTS 64; for overlapping MKF 621 with MKTS 21 per mod - for mod: MKF 664, MKF 621</p>
	<b>MKS 23 C</b>	<p>Kit sovrapposizione forni compatti in AISI 430 H 55 mm per sovrapposizione MKF 623 C a MKF 623 C</p> <p>AISI 430 kit for overlapping compact ovens H 55 mm for overlapping MKF 623 C with MKF 623 C per mod - for mod: MKF 623 C</p>
	<b>MKS 623 C</b>	<p>Kit sovrapposizione forni compatti in AISI 430 H 55 mm per sovrapposizione MKF 623 C a MKT 623 D C</p> <p>AISI 430 kit for overlapping compact ovens H 55 mm for overlapping MKF 623 C with MKT 623 D C per mod - for mod: MKF 623 C</p>
	<b>MKSST 623 C</b>	<p>Kit sovrapposizione forni con supporti teglie in AISI 430, capacità 3 teglie 2/3 GN per sovrapposizione MKF 623 C con MKTS 623 C</p> <p>AISI 430 kit for overlapping ovens with trays supports, capacity of 3 trays 2/3 GN for overlapping MKF 623 C with MKTS 623 C per mod - for mod: MKF 623 C</p>
	<b>MKS 11 C</b>	<p>Kit sovrapposizione forni compatti in AISI 430 H 55 mm per sovrapposizione MKF 611 C a MKF 611 C</p> <p>AISI 430 kit for overlapping compact ovens H 55 mm for overlapping MKF 611 C with MKF 611 C per mod - for mod: MKF 611 C</p>
	<b>MKS 611 C</b>	<p>Kit sovrapposizione forni compatti in AISI 430 H 55 mm per sovrapposizione MKF 611 C a MKSST 611 C; per sovrapposizione MKF 1011 C a MKTS 11 C</p> <p>AISI 430 kit for overlapping compact ovens H 55 mm for overlapping MKF 611 C with MKSST 611 C; for overlapping MKF 1011 C with MKTS 11 C per mod - for mod: MKF 611 C, MKF 1011 C</p>
	<b>MKSST 611 C</b>	<p>Kit sovrapposizione forni compatti con supporti teglie in AISI 430, capacità 3 teglie 1/1 GN per sovrapposizione MKF 611 C a MKT 11 D C oppure a MKTS 11 C</p> <p>AISI 430 kit for overlapping compact ovens with trays supports, capacity of 3 trays 1/1 GN for overlapping MKF 611 C with MKT 11 D C or with MKTS 11 C per mod - for mod: MKF 611 C</p>
	<b>KIT LOVE COOKING</b>	<p>Kit teglie composto da: KT9G (2 pz), KFT9G (2 pz), KG9GX (2 pz), KPGR11A (1 pz), MKT11RG (1 pz), EKTF11 (1 pz), EKTF11PT/A (1 pz), KGP (1 pz)</p> <p>Trays kit consisting of: KT9G (2 pcs), KFT9G (2 pcs), KG9GX (2 pcs), KPGR11A (1 pc), MKT11RG (1 pc), EKTF11 (1 pc), EKTF11PT/A (1 pc), KGP (1 pc)</p>
	<b>EKA CLOUD</b>	<p>Connessione al portale Eka Cloud, con validità 3 anni per mod: tutti i forni millennial TS</p> <p>Connection to the Eka Cloud, valid for 3 years for mod: all TS millennial ovens</p>
	<b>EKA PLATINUM</b>	<p>Garanzia 36 mesi per forni Touch Screen e Black Mask con lavaggio</p> <p>36 months warranty for Touch Screen and Black Mask ovens with washing</p>
	<b>EKA GOLD</b>	<p>Garanzia 36 mesi per forni Black Mask senza lavaggio</p> <p>36 months warranty for Black Mask ovens without washing</p>

# Teglie e griglie

## Trays and grids



**Teglie e griglie per forni 2/3 GN**  
Trays and grids for 2/3 GN ovens

**FOOD CONTACT  
CERTIFICATE**



**KT6G**

Teglia in AISI 304 2/3 GN

AISI 304 Tray 2/3 GN  
354 x 325 x 23 mm  
per mod - for mod: MKF 623 C



**KG6X**

Griglia in AISI 304 2/3 GN

AISI 304 grid 2/3 GN  
353 x 325 x 11 mm  
per mod - for mod: MKF 623 C

**Teglie e griglie per forni 2/1 GN**  
Trays and grids for 2/1 GN ovens



**KT21G**

Teglia in AISI 304 2/1 GN  
per mod: tutti i forni millennial 2/1 GN

AISI 304 Tray 2/1 GN  
for mod: all millennial ovens 2/1 GN  
650 x 530 x 42 mm



**KG21G**

Griglia in AISI 304 2/1 GN  
per mod: tutti i forni millennial 2/1 GN

AISI 304 grid 2/1 GN  
for mod: all millennial ovens 2/1 GN  
650 x 530 x 11 mm

**Teglie e griglie per forni 1/1 GN**  
Trays and grids for 1/1 GN ovens



**KT9G**

Teglia in AISI 304 1/1 GN  
per mod: tutti i forni millennial 1/1 GN

AISI 304 Tray 1/1 GN  
for mod: all millennial ovens 1/1 GN  
530 x 325 x 40 mm



**KT9G2**

Teglia in AISI 304 1/1 GN  
per mod: tutti i forni millennial 1/1 GN

AISI 304 Tray 1/1 GN  
for mod: all millennial ovens 1/1 GN  
530 x 325 x 20 mm

	<b>KFT9G</b>	Teglia forata in AISI 304 1/1 GN per mod: tutti i forni millennial 1/1 GN
		AISI 304 Perforated tray 1/1 GN for mod: all millennial ovens 1/1 GN 530 x 325 x 40 mm
	<b>KFT9G2</b>	Teglia forata in AISI 304 1/1 GN per mod: tutti i forni millennial 1/1 GN
		AISI 304 Perforated tray 1/1 GN for mod: all millennial ovens 1/1 GN 530 x 325 x 20 mm
	<b>KG9G</b>	Griglia cromata 1/1 GN per mod: tutti i forni millennial 1/1 GN
		Chromed grid 1/1 GN for mod: all millennial ovens 1/1 GN 530 x 325 x 12 mm
	<b>KG9GX</b>	Griglia in AISI 304 1/1 GN per mod: tutti i forni millennial 1/1 GN
		AISI 304 grid 1/1 GN for mod: all millennial ovens 1/1 GN 530 x 325 x 12 mm
	<b>KPGL11A</b>	Piastra liscia in alluminio con rivestimento <b>antiaderente</b> 1/1 GN per mod: tutti i forni millennial 1/1 GN
		Smooth plate with <b>non-stick coating</b> 1/1 GN for mod: all millennial ovens 1/1 GN 530 x 325 x 7 mm
	<b>KPGR11A</b>	Piastra rigata in alluminio con rivestimento <b>antiaderente</b> 1/1 GN per mod: tutti i forni millennial 1/1 GN
		Striped plate with <b>non-stick coating</b> 1/1 GN for mod: all millennial ovens 1/1 GN 530 x 325 x 20 mm
	<b>MKT11RG</b>	Teglia in AISI 304 1/1 GN raccogli grasso
		AISI 304 fat drip pan grid 1/1 GN 533 x 345 x 41 mm per mod - for mod: MKF 511, MKF 711, MKF 1111
	<b>EKT11RGC</b>	Teglia in AISI 304 1/1 GN raccogli grasso per forni 6 - 10 teglie <b>compatti</b>
		AISI 304 fat drip pan grid 1/1 GN, for <b>compact</b> ovens 6 -10 trays 531,5 x 330 x 40 mm per mod - for mod: MKF 611 C, MKF 1011 C
	<b>KGP</b>	Griglia in AISI 304 1/1 GN per <b>cottura</b> verticale di nr. <b>8 polli</b>
		AISI 304 vertical <b>cooking</b> grid for <b>8 chicken</b> 1/1 GN 530 x 325 x 148,1 mm per mod - for mod: MKF 511, MKF 711, MKF 1111, MKF 611 C, MKF 1011 C
	<b>KGC075</b>	Griglia in AISI 304 1/1 GN per <b>cottura costicine</b>
		AISI 304 grid for <b>cooking ribs</b> 1/1 GN 530 x 325 x 123 mm per mod - for mod: MKF 511, MKF 711, MKF 1111, MKF 611 C, MKF 1011 C
	<b>EKTF11</b>	Teglia forata in AISI 304 1/1 GN per <b>cottura nuggets</b>
		AISI 304 Perforated tray 1/1 GN, for <b>cooking nuggets</b> 533 x 330 x 38,5 mm per mod - for mod: MKF 511, MKF 711, MKF 1111, MKF 611 C, MKF 1011 C
	<b>EKTF11PT/A</b>	Teglia in alluminio forata con <b>rivestimento in teflon</b> 1/1 GN per mod: tutti i forni millennial 1/1 GN
		Perforated aluminium tray <b>teflon coated</b> 1/1 GN for mod: all millennial ovens 1/1 GN 530 x 325 x 20 mm

# Modular design 1/1 GN



**MKF 511 - 5 teglie/trays**

MKM 1211 + MKSST 511  
+ MKF 511 TS\*\* + MKKC 5

\*\*Disponibile versione BM, G TS e G BM (senza cappa)  
\*\*BM version available, G TS and GBM (without hood)

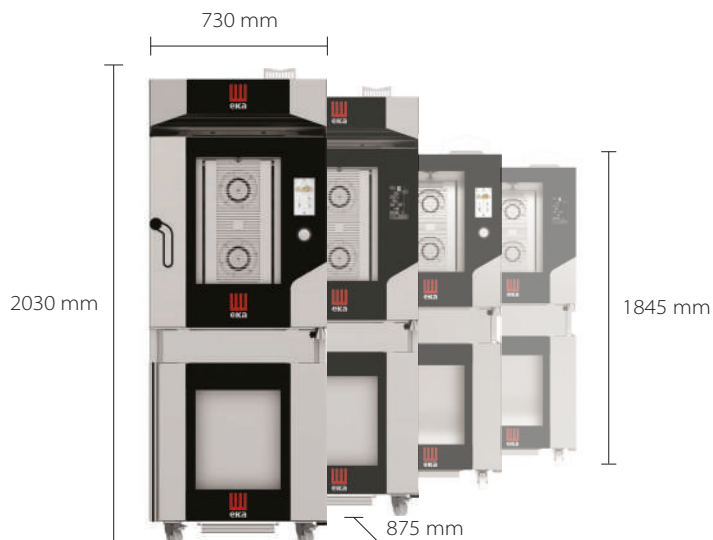

**MKF 711 - 7 teglie/trays**

MKM 1211 + MKST 711  
+ MKF 711 TS\*\* + MKKC 711

\*\*Disponibile versione BM, G TS e G BM (senza cappa)  
\*\*BM version available, G TS and GBM (without hood)



**MKF 1111 - 11 teglie/trays**

MKM 1211 + MKS 11  
+ MKF 1111 TS\*\* + MKKC 711

\*\*Disponibile versione BM, G TS e G BM (senza cappa)  
\*\*BM version available, G TS and GBM (without hood)

**MKF 511 - 5 teglie/trays**

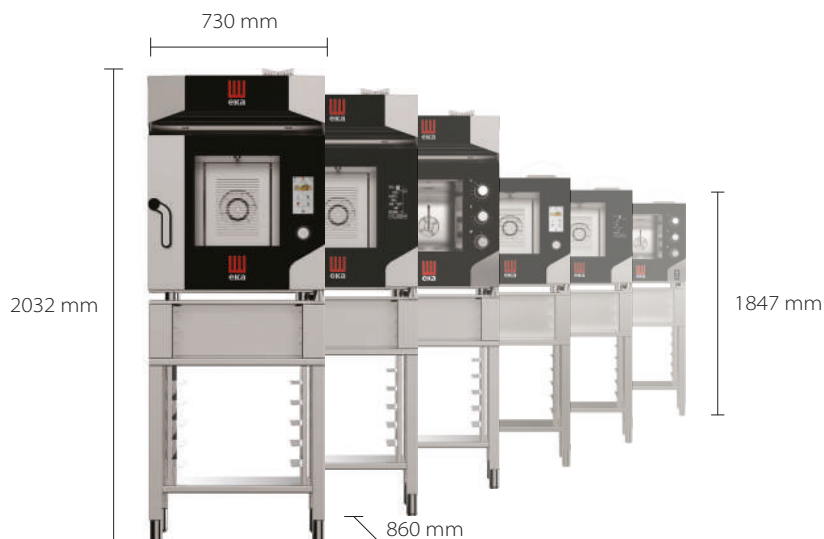

MKTS 11 + MKSST 511  
+ MKF 511 TS\*\* + MKKC 5\*\*\*

\*\*Disponibile versione BM, S e  
G TS, G BM, G S (senza cappa)

\*\*\*Disponibile versione MKKC 5 S per forno S

\*\*BM, S version available, G TS, G BM, G S (without hood)

\*\*\*MKKC 5 S version available for S oven

**MKF 711 - 7 teglie/trays**

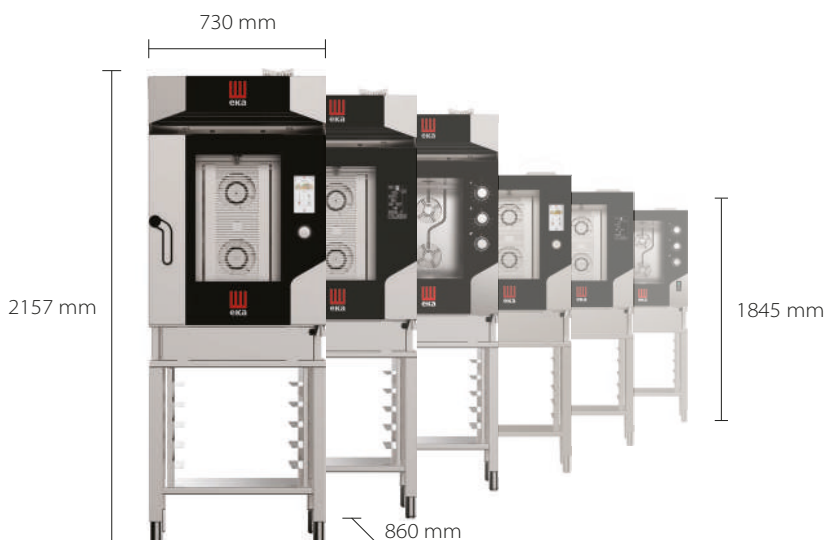

MKTS 11 + MKST 711  
+ MKF 711 TS\*\* + MKKC 711\*\*\*

\*\*Disponibile versione BM, S e  
G TS, G BM, G S (senza cappa)

\*\*\*Disponibile versione MKKC 711 S per forno S

\*\*BM, S version available, G TS, G BM, G S (without hood)

\*\*\*MKKC 711 S version available for S oven

**MKF 1111 - 11 teglie/trays**



MKTS 11 + MKS 11  
+ MKF 1111 TS\*\* + MKKC 711\*\*\*

\*\*Disponibile versione BM, S e  
G TS, G BM, G S (senza cappa)

\*\*\*Disponibile versione MKKC 711 S per forno S

\*\*BM, S version available,  
G TS, G BM, G S (without hood)

\*\*\*MKKC 711 S version available for S oven

**MKF 2011 - 20 teglie/trays**

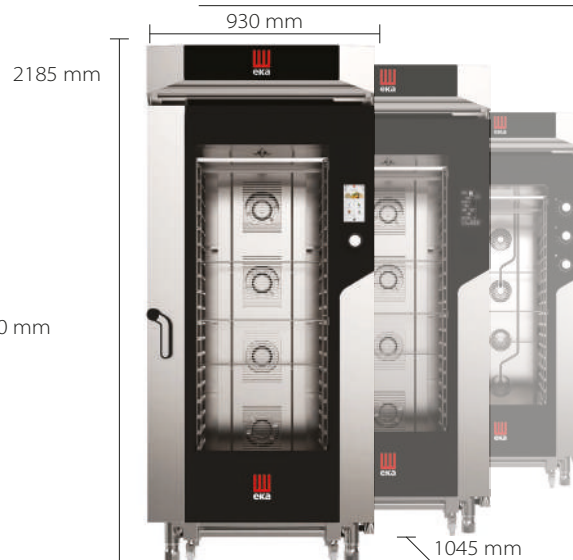

MKF 2011 TS\*\* + MKKC 1620\*\*\*

\*\*Disponibile versione BM e S  
\*\*\*Disponibile versione MKKC 1620 S  
per forno S

\*\*BM, S version available  
\*\*\*MKKC 1620 S version  
available for S oven

# Modular design 1/1 GN

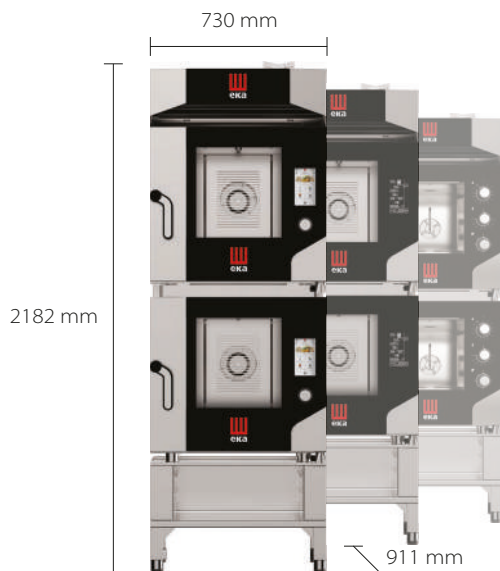

**MKF 511 - 5 + 5 teglie/trays**

\* MKT 11 D + MKSST 511 + MKF 511 TS\*\*  
+ MKS 11 + MKF 511 TS\*\* + MKKC 711\*\*\* + MKCKIT

\*\*Disponibile versione BM e S  
\*\*\*Disponibile versione MKKC 711 S per forno S



**MKF 711 - 7 + 7 teglie/trays**

\* MKT 11 D + MKS 11 + MKF 711 TS\*\*  
+ MKS 11 + MKF 711 TS\*\* + MKKC 711\*\*\* + MKCKIT

\*\*Disponibile versione BM e S  
\*\*\*Disponibile versione MKKC 711 S per forno S



**MKF 1111 - MKF 511  
11 + 5 teglie/trays**

\* MKT 11 D + MKS 11 + MKF 1111 TS\*\*  
+ MKS 11 + MKF 511 TS\*\* + MKKC 711\*\*\* + MKCKIT

\*\*Disponibile versione BM e S  
\*\*\*Disponibile versione MKKC 711 S per forno S

\* In caso di sovrapposizione tra due forni la profondità totale della colonna aumenta di 62 mm  
\* In case of overlap between two ovens the total depth of the column increases by 62 mm

\*\*BM, S version available  
\*\*\*MKKC 711 S version available for S oven

**MKF 621 - 6 teglie/trays**

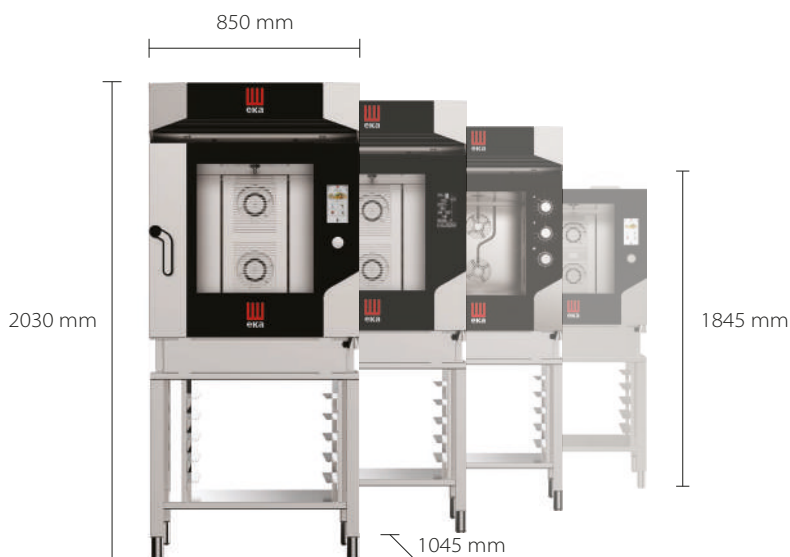

**Modular design  
2/1 GN**

MKTS 21 + MKST 664  
+ MKF 621 TS\*\* + MKKC 610\*\*\*

\*\*Disponibile versione BM, S e G TS (senza cappa)  
\*\*\*Disponibile versione MKKC 610 S per forno S

**MKF 1021 - 10 teglie/trays**



MKTS 21 + MKS 64  
+ MKF 1021 TS\*\* + MKKC 610\*\*\*

\*\*Disponibile versione BM, S e G TS (senza cappa)  
\*\*\*Disponibile versione MKKC 610 S per forno S

**MKF 621 - 6 + 6 teglie/trays**



\* MKT 64 D + MKS 64 + MKF 621 TS\*\*  
+ MKS 64 + MKF 621 TS\*\* + MKKC 610\*\*\* + MKCKIT

\*\*Disponibile versione BM, S  
\*\*\*Disponibile versione MKKC 610 S per forno S

\* In caso di sovrapposizione tra due forni la profondità totale della colonna aumenta di 62 mm  
\* In case of overlap between two ovens the total depth of the column increases by 62 mm

\*\*BM, S version available  
\*\*\*MKKC 610 S version available for S oven

# Modular design COMPACT



### MKF 623 - 6 teglie/trays

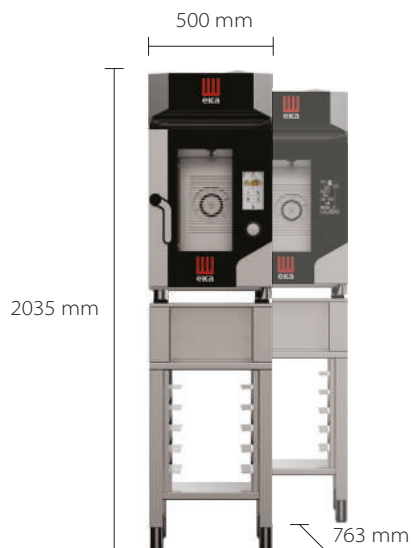

MKTS 623 C + MKSST 623 C +  
MKF 623 CTS\*\* + MKKC 623 C

\*\*Disponibile versione BM  
\*\*BM version available



MKT 623 D C + MKS 623 C + MKF 623 CTS  
+ MKS 23 C + MKF 623 CTS +  
MKKC 623 C + MKCKIT

\*\*Disponibile versione BM  
\*\*BM version available

### MKF 611 - 6 teglie/trays



MKTS 11 C + MKSST 611 C  
+ MKF 611 CTS\*\* + MKKC 610 C

\*\*Disponibile versione BM  
\*\*BM version available

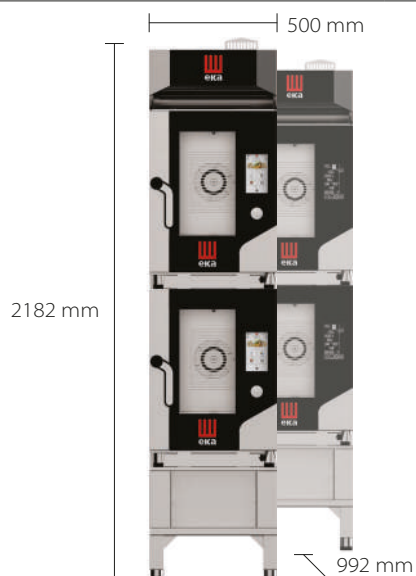

\* MKT 11 D C + MKSST 611 C + MKS 611 C  
+ MKF 611 CTS\*\* + MKS 11 C + MKF 611 CTS\*\* +  
MKKC 610 C + MKCKIT

\*\*Disponibile versione BM  
\*\*BM version available

### MKF 1011 - 10 teglie/trays



MKTS 11 C + MKS 11 C  
+ MKF 1011 CTS + MKKC 610 C

\*\*Disponibile versione BM  
\*\*BM version available

\* In caso di sovrapposizione tra due forni la profondità totale della colonna aumenta di 62 mm  
\* In case of overlap between two ovens the total depth of the column increases by 62 mm

	MKF 511 S	MKF 511 BM	MKF 511 TS	MKF 711 S	MKF 711 BM	MKF 711 TS	MKF 711 VTS	MKF 1111 S	MKF 1111 BM	MKF 1111 TS	MKF 1111 VTS	MKF 2011 S	MKF 2011 BM	MKF 2011 TS	MKF 2011 2VTS	MKF 621 S	MKF 621 BM	MKF 621 TS	MKF 1021 S	MKF 1021 BM
MKM 1211		●	●		●	●	●		●	●	●									
MKL 1064 S																				
MKLM 1064																				
MKCC 5 S	●																			
MKCC 5		●	●																	
MKCC 711 S	●			●				●												
MKCC 711		●	●		●	●	●		●	●	●									
MKCC 1620 S												●								
MKCC 1620													●	●	●					
MKCC 623 C																				
MKCC 610 C																				
MKCC 4 S																				
MKCC 4																				
MKCC 610 S																●			●	
MKCC 610																	●	●		●
MKTS 11	●	●	●	●	●	●	●	●	●	●	●									●
MKT 11 D	●	●	●	●	●	●	●	●	●	●	●									
MKTS 21																●	●	●	●	●
MKTS 623 C																				
MKT 623 D C																				
MKTS 11 C																				
MKT 11 D C																				
MKTPL					●	●			●	●										
MKTS 64																				
MKT 64 D																●	●	●		
MKTSD 2T																				
EKCR 20 TC												●	●	●	●					
EKCR 16 TC																				
EKCR 1664																				
EKKD	●	●	●	●	●	●	●	●	●	●	●	●	●	●	●	●	●	●	●	●
MKSCMO			●							●	●									
MKSCMU/B			●							●	●									
MKSCSV			●							●	●									
MKSSC/A			●							●	●									
EKSCS		●			●				●				●				●			●
MKAF	●	●	●	●	●	●	●	●	●	●	●	●	●	●	●	●	●	●	●	●
MKCG		●	●		●	●	●		●	●	●		●	●	●		●	●	●	●
EKFA	●	●	●	●	●	●	●	●	●	●	●	●	●	●	●	●	●	●	●	●
RCA	●	●	●	●	●	●	●	●	●	●	●	●	●	●	●	●	●	●	●	●
MKBZ			●							●	●									
MKWT		●			●				●				●				●			●
MKDET		●	●		●	●	●		●	●	●		●	●	●		●			●
MKDETS		●	●		●	●	●		●	●	●		●	●	●		●			●
MKCA	●	●	●	●	●	●	●	●	●	●	●	●	●	●	●	●	●	●	●	●
MKKPI	●	●	●	●	●	●	●	●	●	●	●	●	●	●	●	●	●	●	●	●
MKKPIC																				
MKCKIT		●	●		●	●	●		●	●	●					●	●			●
MKCSKIT	●			●				●								●			●	
MKS 11	●	●	●	●	●	●	●	●	●	●	●									
MKS 23 C																				
MKS 623 C																				
MKS 11 C																				
MKS 611 C																				
MKST 711				●	●	●	●													
MKSST 511	●	●	●																	
MKSST 623 C																				
MKSST 611 C																				
MKS 64																●	●	●	●	●
MKST 664																●	●	●	●	●
MKSST 464																				
KT9G	●	●	●	●	●	●	●	●	●	●	●	●	●	●	●					
KT9G2	●	●	●	●	●	●	●	●	●	●	●	●	●	●	●					
KFT9G	●	●	●	●	●	●	●	●	●	●	●	●	●	●	●					
KFT9G2	●	●	●	●	●	●	●	●	●	●	●	●	●	●	●					
KG9G	●	●	●	●	●	●	●	●	●	●	●	●	●	●	●					
KG9GX	●	●	●	●	●	●	●	●	●	●	●	●	●	●	●					
KPGL11A	●	●	●	●	●	●	●	●	●	●	●	●	●	●	●					
KPGR11A	●	●	●	●	●	●	●	●	●	●	●	●	●	●	●					
MKT11RG	●	●	●	●	●	●	●	●	●	●	●									
EKT11RGC																				
KGP	●	●	●	●	●	●	●	●	●	●	●									
KGC075	●	●	●	●	●	●	●	●	●	●	●									
EKTF11	●	●	●	●	●	●	●	●	●	●	●									
EKTF11PT/A	●	●	●	●	●	●	●	●	●	●	●	●	●	●	●					
KT6G																				
KG6X																				
KT21G																●	●	●	●	●
KG21G																●	●	●	●	●





eka  
Fridge-Free  
Soft Drinks  
Energy  
Tea  
Coffee  
ika

  
eka

# COOKING



#### PT MULTI FLASHINDO KARISMA

##### □ JAKARTA (*Head Office*)

Jl. Hayam Wuruk 114 Blok A No. 4  
Maphar, Jakarta - Indonesia 11160  
Telepon : +62 21 626 8758  
Whatsapp : +62 811 1210 6803  
Email : sales.dept@mfk.co.id

##### □ SURABAYA

Ruko Royal Crown Palace RA 2  
Jl. H. Anwar Hamzah, Kp. Baru, Tambakoso,  
Kec. Waru, Kab. Sidoarjo, Jawa Timur 61256  
Telepon : +62 31 3592 9091  
Whatsapp : +62 811 1210 6803  
Email : sales.sby@mfk.co.id

##### □ BALI

Jl. Sunset Road No.108 B, Kec. Kuta  
Kel. Badung, Bali - Indonesia 80361  
Telepon : +62 361 934 2633  
Whatsapp : +62 811 1210 6803  
Email : sales.bali@mfk.co.id

##### □ SERVICE CENTER

Jl. Kamal Raya No.9 Unit B, RT 01/ RW 06  
Tegal Alur, Cengkareng - Indonesia 11820  
Telepon : +62 21 5595 2523  
Whatsapp : +62 811 9144 614  
Email : service.center@mfk.co.id