



## EVOX FT



MODEL	DESCRIPTION
FT20.80	BLAST CHILLER DEEP FREEZER - CAP 20 TRAY 80KG

Rangkaian lengkap Blast Chiller-Freezer Profesional, andal, inovatif, dan berkinerja tinggi. SINCOLD Blast Chillers memenuhi semua kebutuhan profesional HORECA.

Insulasi struktur dalam DPO-0 poliuretan bebas CFC. Pintu yang dapat menutup sendiri dilengkapi dengan paking silikon yang tahan terhadap suhu dingin. Pintu bermagnet dan tahan terhadap suhu panas.

### FITUR :

- Struktur di stainless steel AISI 304 18/10 –Eksternal: scotch bride , interior: mengkilap
- Menggunakan refrigerant high performance Italy yg telah bersertifikat
- Telah menggunakan kipas spesial untuk temperatur rendah dengan sistem regulasi
- Pada ruang bagian dalam sisi sudut dibuat melengkung agar area mudah dibersihkan .
- Menggunakan kondenser heavyduty yang dapat diandalkan  
Telah menggunakan unit Evaporator yang di buat agar tahan karat dan korosi

### FT20.80

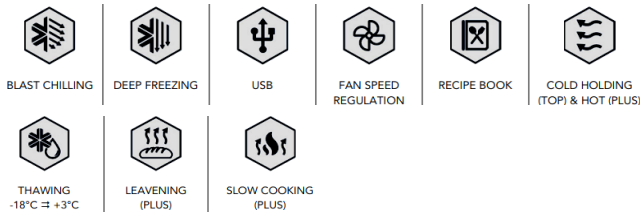

### Special functions:

- Recipe book
- Automatic control on core probe insertion
- raw fish sanitation
- Thawing
- Manual defrost
- Special cycle for ice cream
- Drying
- Evaporator fan speed regulation
- USB
- Evaporator fan speed regulation
- Chamber drying to remove humidity



### Accessories Optional

**PLUS** **ACC F05**  
Leavening cycles and Slow Cooking

**Multipoint Core Probe**

**ACC 509**  
Suitable For WIFI Connection

### SPESIFIKASI :

Model	Capacity Trays	Cap. Blast Chilling	Cap. Blast Freezer	Power 400V/3Ph	Refrigeration power	Refrigeration power	Net Weight	Dimension Unit (L x W x H) mm
<b>FT20.80</b>	20 GN 1/1 (20 EN 60x40)	80 KG 90°C ~ 3°C 90 minutes	50 KG 90°C ~ -18°C 240 minutes	4,8 kW 15,5 A	9.700 W (*Te= -10°C) <70 DB	3.560 W (*Te= -30°C) <70 DB	260 Kg	1150 x 12355 x 2170/2260

\*Te = Expansion temperature - Condensation temperature = +45°C

#### ☐ JAKARTA

Jl. Hayam Wuruk 114 Blok A No. 4, Tamansari.  
Maphar, Jakarta - 11160.  
Phone : (021) 626 8758, 0811 9144 617  
Fax : (021) 625 8473

#### ☐ SURABAYA

Jl. Raya Sarono Jiwo no 4, Prapen Kec. Tenggilis  
Mejoyo. Surabaya - 60299  
Phone : (031) 847 1460, 0811 9611 2726  
Fax : (031) 847 1474

#### ☐ SERVICE CENTER

Bumi Distribution Centre (BDC), Unit B. Jl. Kamal Raya No. 9.  
Cengkareng. Jakarta Barat - 11820  
Phone : (021) 5595 2523, 0811 9144 614  
Fax : (021) 625 8473



Front View

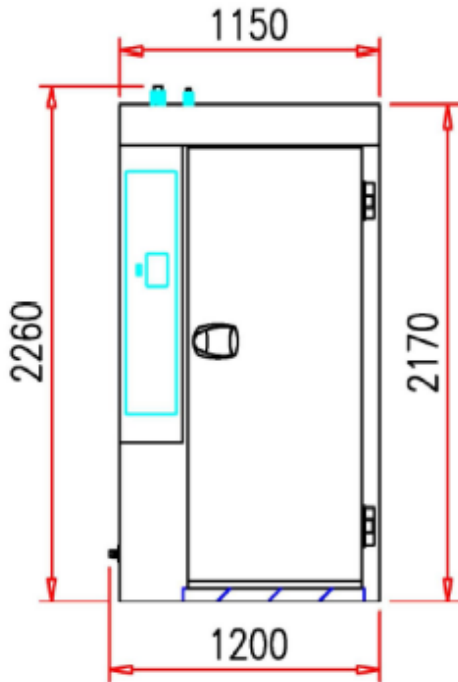

Side View

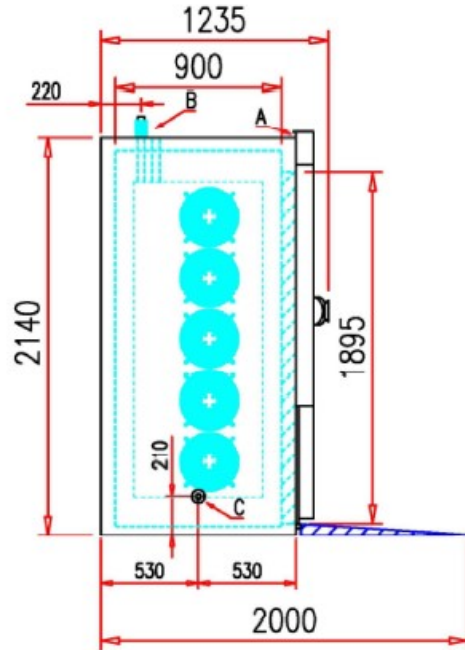

Top View

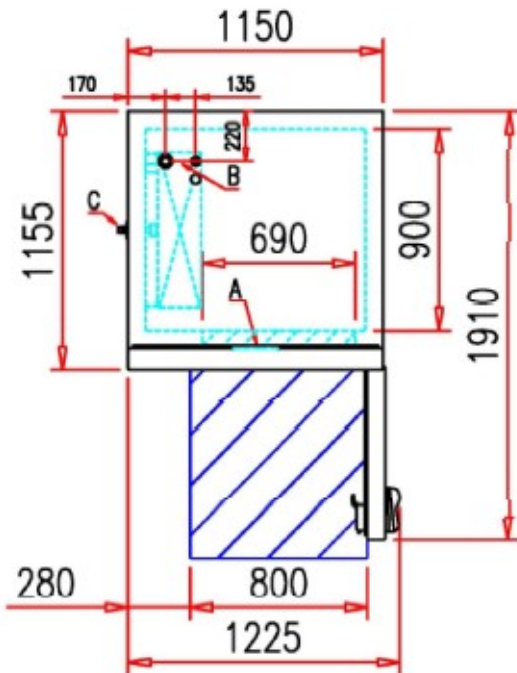

### CONNECTIONS

- A = Electrical and Water connection (when needed)
- B = Refrigeration connection
- C = Evaporator water drain pipe

#### □ JAKARTA

Jl. Hayam Wuruk 114 Blok A No. 4, Tamansari.  
Maphar, Jakarta - 11160.  
Phone : (021) 626 8758, 0811 9144 617  
Fax : (021) 625 8473

#### □ SURABAYA

Jl. Raya Saronno Jiwo no 4, Prapen Kec. Tenggilis  
Mejoyo. Surabaya - 60299  
Phone : (031) 847 1460, 0811 9611 2726  
Fax : (031) 847 1474

#### □ SERVICE CENTER

Bumi Distribution Centre (BDC), Unit B. Jl. Kamal Raya No. 9.  
Cengkareng. Jakarta Barat - 11820  
Phone : (021) 5595 2523, 0811 9144 614  
Fax : (021) 625 8473