



GT 5 PRO

SEMI AUTOMATIC ESPRESSO MACHINE



SEMI AUTOMATIC ESPRESSO MACHINE

MODEL: GT 5 PRO



Gaggia Milano GT 5 Pro adalah semi-automatic espresso machine elektrik dengan layout 2 group, boiler 13 Lt, steam wand, dan hot water outlet untuk operasional espresso berbasis barista.

Mesin ini menggunakan keypad + Display TFT dengan 2.8" colour LCD Display, serta 4 programmable coffee doses dan continuous button pada setiap group. Fitur Autosteam / Autosteam 2.0 mendukung proses steaming yang lebih terkontrol.

Model ini sesuai untuk café, restaurant, hotel, dan coffee bar yang membutuhkan mesin espresso tradisional dengan workflow barista harian.

Fitur:

- Sistem mesin espresso elektrik semi-automatic
- Layout brewing 2 group
- Kapasitas boiler: 13 Lt
- User interface Keypad + Display TFT
- 2.8" colour LCD Display
- 4 programmable coffee doses dan continuous button pada setiap group
- Autosteam / Autosteam 2.0
- Rotational stainless steel steam outlet
- Lateral hot water wand
- Height from output coffee to grid: 87 mm
- Boiler insulation dan heating cycle optimization
- Illuminating working area dan side panels
- Quarter turn tap mechanism
- Compact footprint design
- Referensi glass design

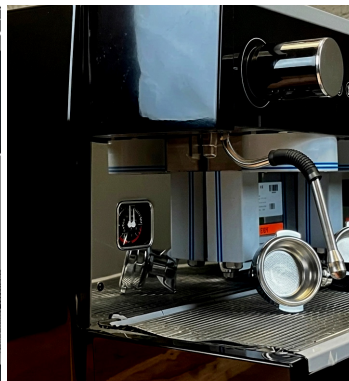

PT MULTI FLASHINDO KARISMA



JAKARTA (Head Office)
Jl. Hayam Wuruk 114 Blok A No. 4
Maphar, Jakarta - Indonesia 11160
Telepon : +62 21 626 8758
Whatsapp : +62 811 1210 6803
Email : sales.dept@mfk.co.id

SURABAYA
Ruko Royal Crown Palace RA 2
Jl. H. Anwar Hamzah, Kp. Baru, Tambakoso,
Kec. Waru, Kab. Sidoarjo, Jawa Timur 61256
Telepon : +62 31 3592 9091
Whatsapp : +62 811 1210 6803
Email : sales.sby@mfk.co.id

BALI
Jl. Sunset Road No.108 B, Kec. Kuta
Kel. Badung, Bali - Indonesia 80361
Telepon : +62 361 934 2633
Whatsapp : +62 811 1210 6803
Email : sales.bali@mfk.co.id

SERVICE CENTER
Jl. Kamal Raya No.9 Unit B. RT 01/ RW 06
Tegal Alur, Cengkareng - Indonesia 11820
Telepon : +62 21 5595 2523
Whatsapp : +62 811 9144 614
Email : service.center@mfk.co.id



www.mfk.co.id
FOOD SERVICE EQUIPMENT & SUPPLIES

GT 5 PRO

SEMI AUTOMATIC ESPRESSO MACHINE



SPESIFIKASI:

MODEL: GT 5 PRO	
Dimensi (p x l x t)	: 760 × 530 × 468 mm
Jumlah Group Head	: 2 Group
Kapasitas Boiler	: 13 L
Daya Listrik	: 3,750 W
Tegangan	: 220 - 230 V / 50 - 60 Hz
User Interface	: Keypad + TFT Display
Ukuran Layar	: 2.8" Colour LCD Display
Warna	: Hitam & Abu-abu (Silver)
Berat	: 55 kg

DIMENSI:

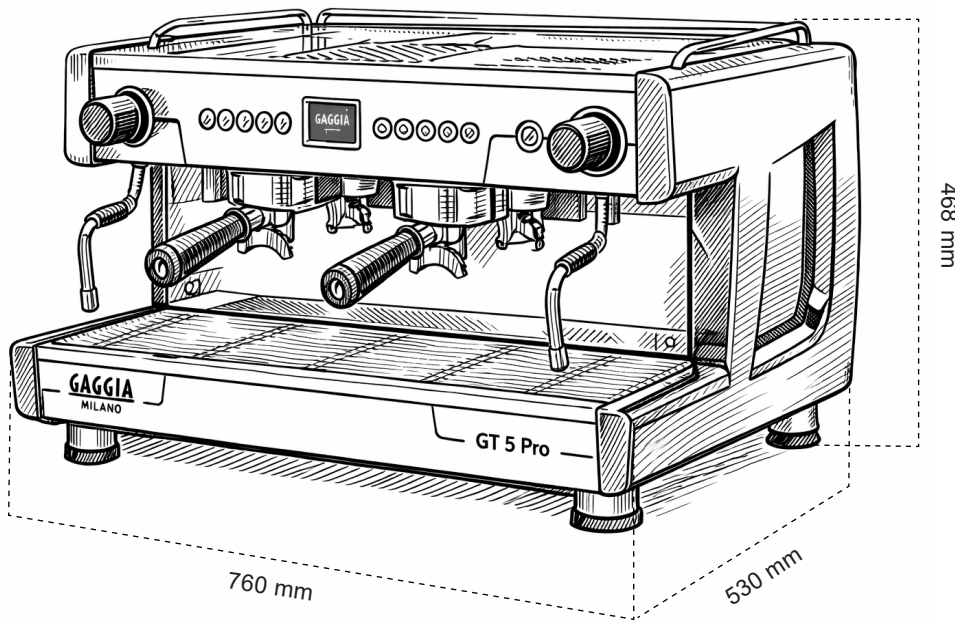

PT MULTI FLASHINDO KARISMA

□ JAKARTA (Head Office)
Jl. Hayam Wuruk 114 Blok A No. 4
Maphar, Jakarta - Indonesia 11160
Telepon : +62 21 626 8758
Whatsapp : +62 811 1210 6803
Email : sales.dept@mfk.co.id

□ SURABAYA
Ruko Royal Crown Palace RA 2
Jl. H. Anwar Hamzah, Kp. Baru, Tambakoso,
Kec. Waru, Kab. Sidoarjo, Jawa Timur 61256
Telepon : +62 31 3592 9091
Whatsapp : +62 811 1210 6803
Email : sales.sby@mfk.co.id

□ BALI
Jl. Sunset Road No.108 B, Kec. Kuta
Kel. Badung, Bali - Indonesia 80361
Telepon : +62 361 934 2633
Whatsapp : +62 811 1210 6803
Email : sales.bali@mfk.co.id

□ SERVICE CENTER
Jl. Kamal Raya No.9 Unit B. RT 01/ RW 06
Tegal Alur, Cengkareng - Indonesia 11820
Telepon : +62 21 5595 2523
Whatsapp : +62 811 9144 614
Email : service.center@mfk.co.id