



Item No : _____
 Electrical : _____
 Options : _____
 Price : _____

Fully Automatic Ventless Countertop Deep Fryer



- ✓ Fully automated cooking system
- ✓ Front loading / front dispensing
- ✓ Small footprint
- ✓ Programmable presets
- ✓ Odorless
- ✓ Integral ventless hood
- ✓ Largest output
- ✓ Easy to clean
- ✓ Fully enclosed
- ✓ Optional infra-red, ceramic heat lamp and oil drainage kit
- ✓ Non-stick basket

Model: DSA300

SPECIFICATION	DSA300
Power Supply (Volts)	: 240
Current (Amps)	: 12.5
Circuit Current (Amps)	: Min 16***
Cord Option	: Field Wired
Power (Kilowatts)	: 3.0
Capacity (Kg/Hr)	: 18 Kg (40 Lbs)
Heater Element (Kilowatts)	: 3.0
Phase	: Single Phase (3 Wire), 3 Phase (5 Wire)
Cycles	: 50/60 Hz
Weight	: 57 Kg (125 Lbs)
Machine Dimensions (DxWxH)	: 635mm x 559mm x 762mm
Oil Capacity	: 11 L (7.75 US Gallons)
Product Capacity	: 3 Lbs per load

* Continuing research results in steady improvements; therefore, these specifications are subject to change without prior notice



Jl. Hayam Wuruk 114 Block A4. Jakarta – 11160. Indonesia. Telp: (021) 626 8758. Fax: (021) 629 4255. Email: sales.dept@mfk.co.id
 Surabaya : Jl. Sarono Jiwo No.4 - Surabaya 60299 Telp. (62-31) 8471460, Fax. (62-31) 8471474

www.mfk.co.id
sales.dept@mfk.co.id
 mfk pt
 MFK Channel
 mfk_pt
 MFK PT
 MFK PT
 MFK PT



Fully Automatic Ventless Countertop Deep Fryer

Model: DSA300

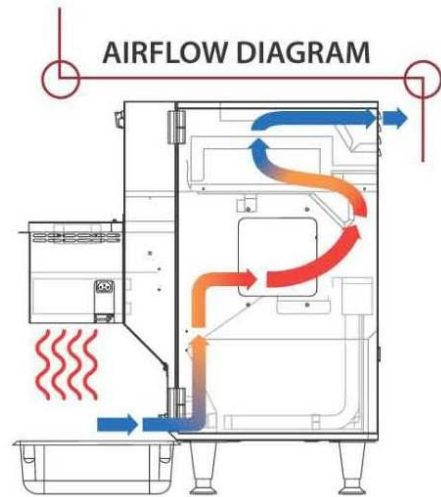
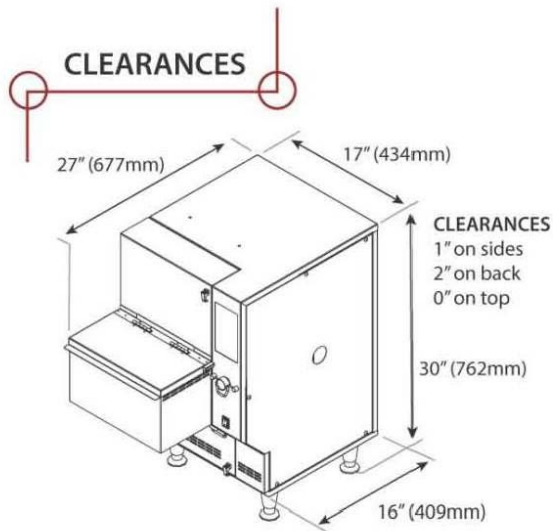

RAPIDFRY™ TECHNOLOGY

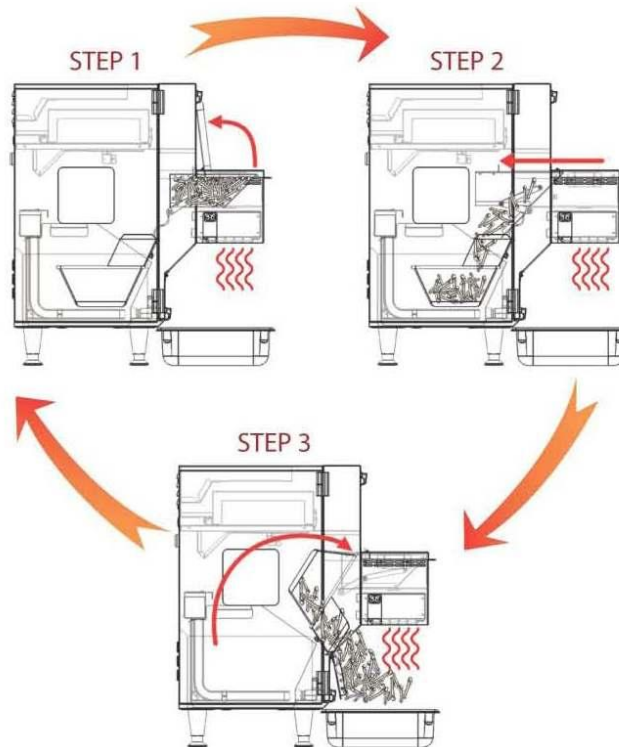

Jl. Hayam Wuruk 114 Block A4. Jakarta – 11160. Indonesia. Telp: (021) 626 8758. Fax: (021) 629 4255. Email: sales.dept@mfk.co.id
 Surabaya : Jl. Sarono Jiwo No.4 - Surabaya 60299 Telp. (62-31) 8471460, Fax. (62-31) 8471474

www.mfk.co.id
sales.dept@mfk.co.id
 mfk pt
 MFK Channel
 mfk_pt
 MFK PT
 MFK PT
 MFK PT