



www.mfk.co.id
FOOD SERVICE EQUIPMENT & SUPPLIES

RT-156MC-S

UNDERCOUNTER REFRIGERATOR 2 DOORS



UNDERCOUNTER REFRIGERATOR 2 DOORS



MODEL: RT-156MC-S

Hoshizaki RT-156MC-S adalah undercounter refrigerator berbasis sistem pendingin elektrik yang dirancang untuk penyimpanan dingin, menggunakan refrigerant R290 dengan rentang pengaturan suhu -6 to 12°C.

Unit ini beroperasi dengan power supply 1 Phase 220-240V 50Hz dan electric consumption 2.15kWh/day. Sistem dilengkapi dengan large and clear display, self-closing door, LED lighting, dan drainage-free design untuk mendukung operasional dapur komersial harian.

Model ini sesuai untuk commercial kitchen, restoran, café, hotel, dan area food preparation yang membutuhkan penyimpanan dingin undercounter dengan storage capacity 322L.

FITUR:

- Sistem pendingin elektrik dengan refrigerant R290
- Temperature control range -6 to 12°C
- Large and clear display
- Self-closing door
- Removal door gaskets
- Round interior corners
- Drainage-free design
- LED lighting
- Powerful cooling performance
- Lower running cost
- 4pcs shelves
- Konfigurasi undercounter
- Compliant with IEC60335-2-89 Standard
- HACCP International Certification
- ISO9001 reference



PT MULTI FLASHINDO KARISMA

□ JAKARTA (Head Office)

Jl. Hayam Wuruk 114 Blok A No. 4
Maphar, Jakarta - Indonesia 11160
Telepon : +62 21 626 8758
Whatsapp : +62 811 1210 6803
Email : sales.dept@mfk.co.id

□ SURABAYA

Ruko Royal Crown Palace RA 2
Jl. H. Anwar Hamzah, Kp. Baru, Tambakoso,
Kec. Waru, Kab. Sidoarjo, Jawa Timur 61256
Telepon : +62 31 3592 9091
Whatsapp : +62 811 1210 6803
Email : sales.sby@mfk.co.id

□ BALI

Jl. Sunset Road No.108 b, Kec. Kuta
Kel. Badung, Bali - Indonesia 80361
Telepon : +62 361 934 2633
Whatsapp : +62 811 1210 6803
Email : sales.bali@mfk.co.id

□ SERVICE CENTER

JL. Kamal Raya No.9 Unit B. RT 01/ RW 06
Tegal Alur, Cengkareng - Indonesia 11820
Telepon : +62 21 5595 2523
Whatsapp : +62 811 9144 614
Email : service.center@mfk.co.id





www.mfk.co.id
FOOD SERVICE EQUIPMENT & SUPPLIES

RT-156MC-S

UNDERCOUNTER REFRIGERATOR 2 DOORS

**SPESIFIKASI:****MODEL: RT-156MC-S**

Dimensi (P x L x T)	: 1500 x 600 x 850 (-880) mm (dengan konfigurasi 2 pintu)
Dimensi Katon Box	: 1565 x 680 x 845 mm
Voltase/ Frekuensi / Phase	: 220 - 240 V / 50-60 Hz / 1 Phase
Kapasitas Daya	: 0.41 kVA (1.86A)
Konsumsi Listrik	: 3.43 kWh / day
Temperature Control	: - 6 hingga 12°C
Kapasitas Penyimpanan	: 322 L
Tipe Refrigeran	: R290
Jumlah Rak	: 4 pcs
Kondisi Operasional	: Suhu lingkungan: 5 - 38°C, toleransi tegangan listrik: rated voltage ±6%
Berat	: 86 kg (nett), 98 kg (gross)

DIMENSI:

Tampilan Bagian Depan

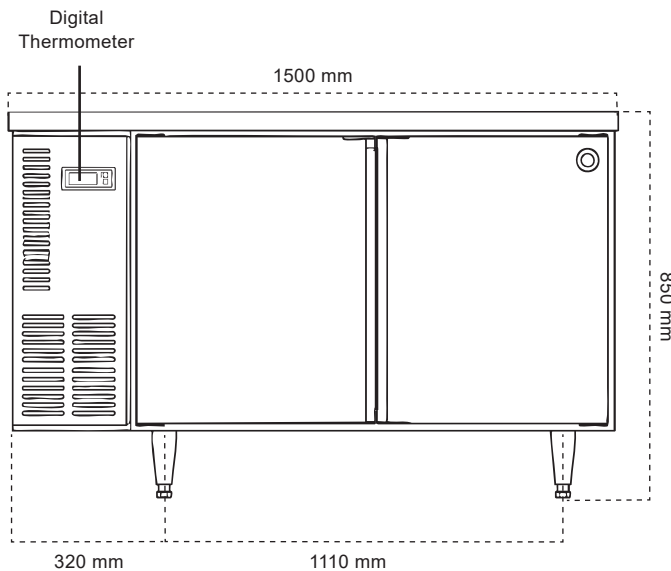

Tampilan Bagian Samping

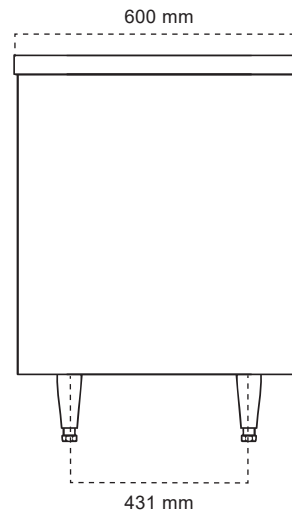
**PT MULTI FLASHINDO KARISMA****□ JAKARTA (Head Office)**

Jl. Hayam Wuruk 114 Blok A No. 4
Maphar, Jakarta - Indonesia 11160
Telepon : +62 21 626 8758
Whatsapp : +62 811 1210 6803
Email : sales.dept@mfk.co.id

□ SURABAYA

Ruko Royal Crown Palace RA 2
Jl. H. Anwar Hamzah, Kp. Baru, Tambakoso,
Kec. Waru, Kab. Sidoarjo, Jawa Timur 61256
Telepon : +62 31 3592 9091
Whatsapp : +62 811 1210 6803
Email : sales.sby@mfk.co.id

□ BALI

Jl. Sunset Road No.108 b, Kec. Kuta
Kel. Badung, Bali - Indonesia 80361
Telepon : +62 361 934 2633
Whatsapp : +62 811 1210 6803
Email : sales.bali@mfk.co.id

□ SERVICE CENTER

JL. Kamal Raya No.9 Unit B. RT 01/ RW 06
Tegal Alur, Cengkareng - Indonesia 11820
Telepon : +62 21 5595 2523
Whatsapp : +62 811 9144 614
Email : service.center@mfk.co.id