



## DISPLAY CABINET

Item No : \_\_\_\_\_ Qty : \_\_\_\_\_  
Electrical : \_\_\_\_\_ Volt : \_\_\_\_\_  
Options : \_\_\_\_\_  
Price : \_\_\_\_\_



**Model: FDWDE-1**

### Features:

- ✓ It holds everything from hot pretzels to 15" (381 mm) pizzas, croissants to bagels, and even hot dogs and meat pies
- ✓ Components, controls and water reservoir are located at the top for easy access. A red light indicates a low water level and a green light shows the humidity cycle
- ✓ Shatter-resistant incandescent light enhances food appeal while safe-guarding food products from bulb breakage
- ✓ Internal thermometer indicates cabinet temperature
- ✓ The Hatco Flav-R-Fresh is ideal for restaurants, pizzerias, convenience stores, concession stands, snack bars, and kiosks

### Specifications

Dimensions (mm)	: 492 x 530 x 727
Cabinet Opening (mm)	: 400 x 502
Power (Watt)	: 1420
Rack Style	: Circle Rack with Rack Motor
Weight (kg)	: 36

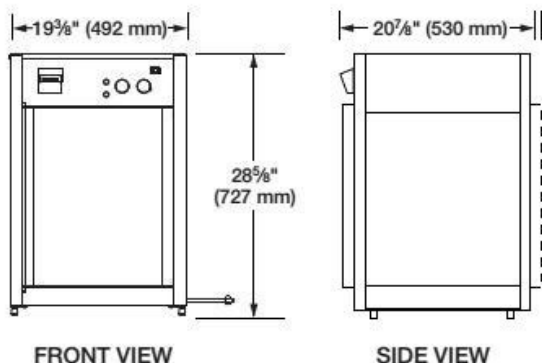

\* Continuing research results in steady improvements; Therefore, these specifications are subject to change without prior notice.

