



# ALPHA-CG300

GAS DIRECT-HEATING PLANETARY COOKING MIXER



## ALPHA-CG300

(Gas Direct-Heating Planetary Cooking Mixer)



### APLIKASI UTAMA:

- Sambal (halus / kasar).
- Chili paste.
- Bumbu masakan dan pasta berbumbu.
- Curry base / gulai base.
- Oil-based seasoning.
- Saus ber-viskositas tinggi.
- Tumisan bumbu aromatik.



## MODEL: ALPHA-CG300

ALPHA-CG300 adalah planetary cooking mixer industri dengan kapasitas besar untuk kebutuhan produksi dapur komersial dan central kitchen. Unit ini memakai gas direct heating dengan bowl SUS304 single-layer, serta planetary mixing dan scraper PTFE untuk mencegah hangus & menjaga konsistensi adonan. Peralatan ini ideal untuk dapur produksi dengan kebutuhan output besar dan stabil, seperti catering, central kitchen, dan industri makanan.

### FITUR:

- **Sistem Pemanasan**  
Pemanasan gas langsung (LPG / Natural Gas), Far-infrared gas burner & tidak menggunakan steam jacket / thermal oil.
- **Sistem Pengadukan**  
Planetary mixer dengan poros fixed (non-removable), 2 pcs PTFE scraper (standar), pengadukan yang kuat untuk produk ber-viskositas tinggi & kecepatan pengadukan dapat diatur.
- **Konstruksi**  
Bowl SUS304 food-grade, ketebalan bowl  $\pm 4$  mm, Interior polished untuk mudah dibersihkan, rangka heavy-duty & gear reduction industrial-grade.
- **Panel Kontrol**  
Panel kontrol dasar, pengaturan kecepatan mixing, kontrol ignition burner & emergency stop.
- **Sistem Keamanan**  
Flame failure protection, gas shut-off safety, overload protection & emergency stop.

### AKSESORIS:

Aksesoris standar terdiri dari; 2 pcs PTFE scraper, planetary mixing arm, gas burner assembly, panel kontrol dasar & sistem manual tilting.



### PT MULTI FLASHINDO KARISMA

#### □ JAKARTA (Head Office)

Jl. Hayam Wuruk 114 Blok A No. 4  
Maphar, Jakarta - Indonesia 11160  
Telepon : +62 21 626 8758  
Whatsapp : +62 811 1210 6803  
Email : sales.dept@mfk.co.id

#### □ SURABAYA

Ruko Royal Crown Palace RA 2  
Jl. H. Anwar Hamzah, Kp. Baru, Tambakoso,  
Kec. Waru, Kab. Sidoarjo, Jawa Timur 61256  
Telepon : +62 31 3592 9091  
Whatsapp : +62 811 1210 6803  
Email : sales.sby@mfk.co.id

#### □ BALI

Jl. Sunset Road No.108 B, Kec. Kuta  
Kel. Badung, Bali - Indonesia 80361  
Telepon : +62 361 934 2633  
Whatsapp : +62 811 1210 6803  
Email : sales.bali@mfk.co.id

#### □ SERVICE CENTER

JL. Kamal Raya No.9 Unit B. RT 01/ RW 06  
Tegal Alur, Cengkareng - Indonesia 11820  
Telepon : +62 21 5595 2523  
Whatsapp : +62 811 9144 614  
Email : service.center@mfk.co.id



# ALPHA-CG300

## GAS DIRECT-HEATING PLANETARY COOKING MIXER

**SPESIFIKASI:****MODEL: ALPHA-CG300 (Gas Direct-Heating Planetary Cooking Mixer)**

Dimensi ( p x l x t )	: ± 1530 × 2134 × 1878 mm
Kapasitas	: 300 Liter (160–220 L efektif per batch).
Sistem Pemanasan	: Gas direct heating.
Burner Standar	: Multi-ring gas burner.
Tipe Gas	: LPG / Natural Gas.
Sistem Pengadukan Planetary	: Poros fixed.
Jumlah Scraper	: 2 pcs PTFE.
Daya Motor Pengaduk	: 2.2 kW (standar).
Opsi Upgrade Motor	: 3.7 kW / 5.5 kW / 7.5 kW.
Daya Sistem Hidrolik	: 1.5 kW.
Material Bowl	: SUS304, ±4 mm
Metode Tilting	: Manual tilting.
Tegangan Listrik	: 380V / 3-Phase / 50Hz (standar).
Frekuensi	: 50Hz / 60Hz.
Berat	: ± 930 kg (Nett), ± 1000 kg (Gross)

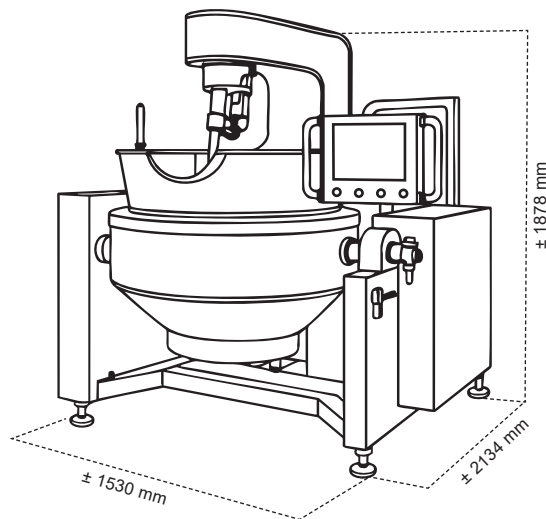
**DIMENSI:**

Tampak Serong Depan

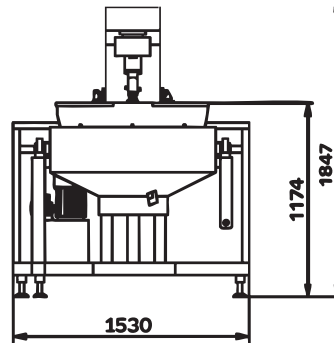

Tampak Depan

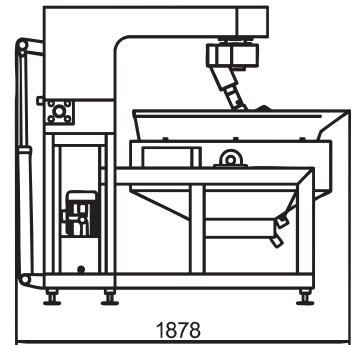

Tampak Samping

**RINGKASAN KELISTRIKAN:****Total Daya Listrik Terpasang: 3.7 kW**

- Motor Mixing: 2.2 kW.
- Sistem Hidrolik: 1.5 kW.
- Panel kontrol: sangat minimal (<0.1 kW).

**Kesesuaian Frekuensi**

- 50 Hz / 60 Hz tidak mengubah konsumsi daya (kW).
- Mixer RPM sedikit lebih tinggi pada 60 Hz.

**OPSIONAL (UPGRADES)**

- Hydraulic auto-tilting.
- Hydraulic lifting.
- PLC touchscreen panel.
- Automatic weighing system.
- Motor upgrade (3.7 / 5.5 / 7.5 kW).
- Upgrade full-body stainless steel.

**PT MULTI FLASHINDO KARISMA****JAKARTA (Head Office)**

Jl. Hayam Wuruk 114 Blok A No. 4  
Maphar, Jakarta - Indonesia 11160  
Telepon : +62 21 626 8758  
Whatsapp : +62 811 1210 6803  
Email : sales.dept@mfk.co.id

**SURABAYA**

Ruko Royal Crown Palace RA 2  
Jl. H. Anwar Hamzah, Kp. Baru, Tambakoso,  
Kec. Waru, Kab. Sidoarjo, Jawa Timur 61256  
Telepon : +62 31 3592 9091  
Whatsapp : +62 811 1210 6803  
Email : sales.sby@mfk.co.id

**BALI**

Jl. Sunset Road No.108 B, Kec. Kuta  
Kel. Badung, Bali - Indonesia 80361  
Telepon : +62 361 934 2633  
Whatsapp : +62 811 1210 6803  
Email : sales.bali@mfk.co.id

**SERVICE CENTER**

JL. Kamal Raya No.9 Unit B. RT 01/ RW 06  
Tegal Alur, Cengkareng - Indonesia 11820  
Telepon : +62 21 5595 2523  
Whatsapp : +62 811 9144 614  
Email : service.center@mfk.co.id