

Item No	:	Qty	:
Electrical	:	Volt	:
Options	:		
Price	:		

Counter Chiller



Features:

- ▶ High-density Cyclo-isopentane Polyurethane insulated body saves energy.
- ▶ Refrigeration system protected from corrosion by urethane-treated evaporator coil.
- ▶ Effective counter – balanced weight system self-closing door provides smooth, even, positive closure.
- ▶ Environmentally friendly refrigerant (CFC and HCFC Free) R134a

Model : BS2DC4/Z

Specifications :

Temperature°C (celsius)	:	+1 to +6
External Dimension (mm)	:	1200 x 760 x 840
Gross Volume (Litres)	:	278
Voltage/ Frequency (V/Hz)	:	230V / 1 / 50Hz
Cooling Capacity (W)	:	530
Wattage (W)	:	380 - 420
Ampere(A)	:	2.8 - 3.2

* Continuing research results in steady improvements; therefore, these specifications are subject to change without prior notice.



PT MULTI FLASHINDO KARISMA

Jakarta

Jl. Hayam wuruk 114 Blok A No. 4
 Jakarta - Indonesia 11160
 Telp. (021) 626 8758,
 Fax. (021) 625 8473

Surabaya :

Jl. Sarono Jiwo No.4
 Surabaya - Indonesia 60299
 Telp. (031) 847 1460,
 Fax. (031) 847 1474

Service Center :

Jl. Kamal Raya No.9 RT01/06, Tegal Alur - Cengkareng
 Telp. (021) 5595 2523/ 2952 8135
 Fax. (021) 5595 7271
 Email: service.center@mfk.co.id

Drawing Detail :

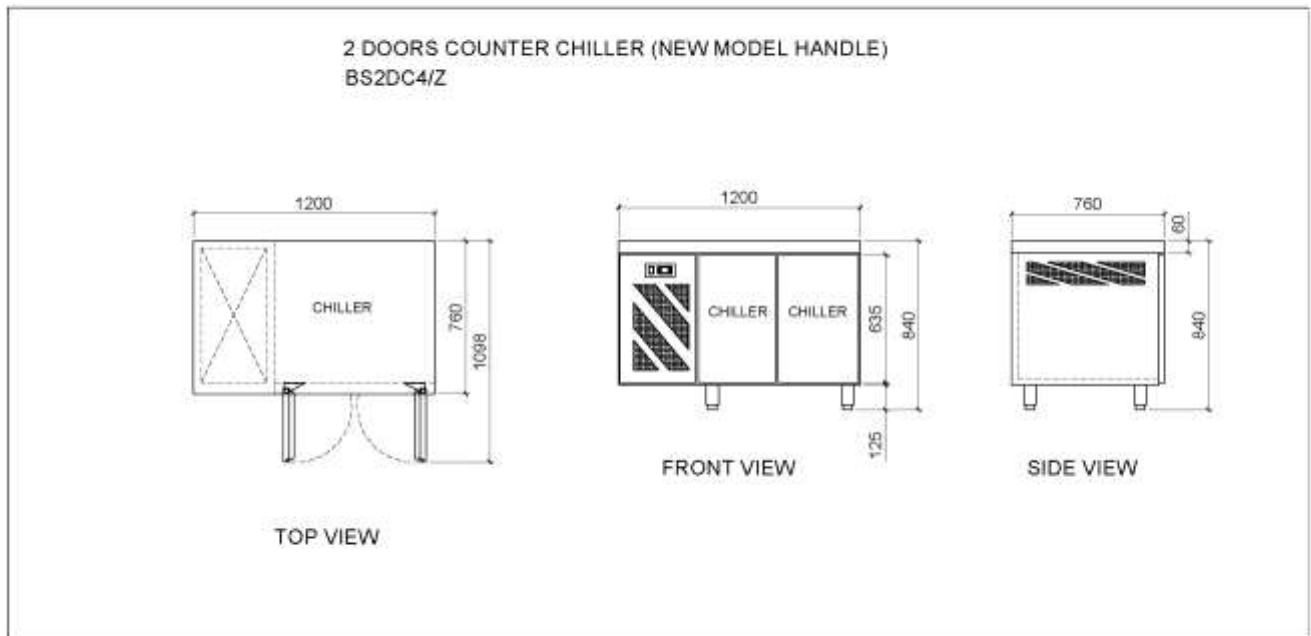

PT MULTI FLASHINDO KARISMA

Jakarta

Jl. Hayam wuruk 114 Blok A No. 4
Jakarta - Indonesia 11160
Telp. (021) 626 8758,
Fax. (021) 625 8473

Surabaya :

Jl. Saroni Jiwo No.4
Surabaya - Indonesia 60299
Telp. (031) 847 1460,
Fax. (031) 847 1474

Service Center :

Jl. Kamal Raya No.9 RT01/06, Tegal Alur - Cengkareng
Telp. (021) 5595 2523/ 2952 8135
Fax. (021) 5595 7271
Email: service.center@mfk.co.id